

Telic SBC3



User Manual

Version 1.3

Please check the version number of this document against the two first digits of the used SBC software version.

July 2011

1 A Word in the Beginning

Thank you for your decision to purchase a professional telematics module from Telic!

The Standard Board Computer 3 (SBC3) from Telic is an innovative telematics unit with flexible I/O capability. It offers a lot of tracking and monitoring options. The SBC3 is available in two versions. The **SBC3-AVL** is focused on tracking and tracing of vehicles with basic I/O functions. **The SBC3-CAN** includes all features of the SBC3-AVL. Additionally it can verify the vehicle data via a CAN-Bus interface. You can also connect further devices to the SBC3-CAN via RS232 and a 1-wire interface.

We wish you a lot of success using your SBC3!

All information and advice in this documentation has been assembled after careful research, but should not to considered as a guaranteed feature set.

The copyright of the related documentation is with Telic GmbH.

Brands

The Telic Logo and the terms Telic, Telic SBC3 are brands of Telic GmbH.

All further names and terms used can be brands or registered brands of their respective owners.

Telic preserves the right to change the included information without prior notice and doesn't take responsibility for errors in the document and/or missing information.

Oberhaching, July 1st, 2011

© 2011 Telic GmbH, Oberhaching, Germany

2 Hints for this User Manual

This documentation has been written for users of the Telic SBC3 telematics device.

A significant number of people have worked on this document, in order to provide the best possible support for users of the SBC3. Nevertheless if you find an error or if you have suggestions in respect to this documentation then please send an email to

E-Mail: support@telic.de

The intention of this documentation is to help you using the various functions of the device in an optimised way. Please go through this user manual carefully.

The following described operating – and configuration possibilities are partly dependent on the tracking platform used in conjunction with the SBC3. On request you can get a Quick Configuration Guide from Telic, how to configure the important parameters independent from the control centre via SMS (e.g. from a mobile phone).

In case you are in a hurry and you want to get more familiar with the details of this product at a later stage, then please go directly to chapter 15 “Quick start” first.

There you can find all the relevant information, for getting the device into operation quickly.

3 Delivery content

The SBC3 gets delivered with a (GSM/GPRS) combo antenna. (glue antenna with connection cable to fix the window dash board)

Available Accessories (not part of the standard delivery):

Combined GSM/GPS window antenna

Connection Cable with 7 wires



Picture showing SBC3 together with the available accessories.

4 Table of content

1	A Word in the Beginning	2
2	Hints for this User Manual	3
3	Delivery content	4
4	Table of content	5
5	Introduction	7
5.1	What is a telematics module?	7
5.2	Operational Range	8
5.3	What does GPRS mean?	8
5.4	Precision of GPS position	9
5.5	What do you need to use the SBC3?	10
5.5.1	Power supply	11
5.5.2	Antennas	11
5.5.3	Mobile GSM Network SIM-Card	11
5.5.4	Please give preference to post paid SIM cards!!	11
5.6	Operation set-up	12
5.6.1	First Step: Open the Device	12
5.6.2	Second Step: Insert the SIM card	12
5.6.3	Switching the device on and off	14
5.6.4	Third Step: Close the Cover	15
5.6.5	Fourth Step: Connecting the antennas	15
5.6.6	Fifth Step: Connecting the unit to the vehicle	16
5.6.7	Sixth Step: Install the Remote Surveillance Module	21
6	The tracking via a tracking programme or tracking server	22
7	General functionality of Telic SBC3	23
8	The digital inputs	24
9	The digital output	24
9.1	Switching the digital output	25
9.2	Automatic answer of the digital output	25
10	The analog input (ANA IN1)	26
10.1	Boardnet-voltage (analog input VCC)	26
10.2	Battery-voltage (analog input battery)	26
11	Additional Features of SBC3 CAN	26
11.1	Serial interface	26

11.2	CAN interface	26
11.3	1-Wire interface	27
11.4	SBC3-CAN wiring description	27
12	Other features	29
12.1	Testing the device	29
12.1.1	Verification by the LEDs	30
12.1.2	The test transmission	31
12.2	Data buffering in case of bad GSM network	32
12.3	Automatic switch off of the Telic SBC3	32
12.4	The integrated Watchdogs	33
13	The status message	33
13.1	Content of a status message	34
13.1.1	Event and Log Codes	35
13.1.2	Mileage counter (in meters)	36
13.2	Sending strategies for status messages	36
13.2.1	Distance based status messages	36
13.2.2	Direction change based status messages	37
13.2.3	Status messages for certain events	37
13.2.4	The speed filter	37
13.3	Hints for some special situations	38
13.3.1	First position of a new route	38
13.3.2	Last position of a new route	38
14	Geofence	38
14.1	Position Lock Alarm	39
15	Quickstart	39
15.1	Hardware installation	39
15.2	Quick test	40
16	Request and change of configuration	40
16.1	SIM card and provider specific parameters	40
16.1.1	PIN-Code of SIM card	40
16.1.2	GPRS Parameter	41
16.2	Systemspecific paramters	41
17	Error handling	43
18	Power consumption	46
19	Technical data	46
20	Accessories	47
21	Document history	48

5 Introduction

5.1 What is a telematics module?

A telematics module is the combination of a compact computer system with various interfaces, a GSM modem (mobile phone without a keypad or display), and a GPS receiver used to receive satellite-supported location information.

But, what does GPS mean?

GPS means "Global Positioning System". Originally, this satellite tracking system was developed by the U.S. Military for its own purposes.

A GPS receiver is able to determine its position on the earth's surface and its height above sea level to within a few meters. To accomplish this amazing feat, 24 satellites at a height of 20,183 km continuously cross our planet in six different patterns. They continuously send location data and time signals using an atomic clock.

GPS receivers simultaneously receive the signals of up to 12 satellites and compare the time of reception with their own built-in clock. Since the satellites operate at different distances from the receiver, the signal delay indicates the distance of the various satellites to the remote surveillance module. Using this difference, the GPS receiver is able to calculate its own position.

In order to transmit three dimensional results - length, height, width - the signals from at least four satellites are necessary.

Through the combination of the above technology, the device can perform surveillance and control tasks and transfer the results to a user via SMS or GPRS – and all this for a price far less than that of a laptop or a PDA with comparable functions.

Remote surveillance modules are available with or without satellite-supported positioning. With the Telic SBC3 unit you have made the choice to use a device with satellite-supported positioning. Therefore, aside from all of the surveillance possibilities of the device, you can also find its precise location and react to any changes in its position.

5.2 Operational Range

The Telic SBC3 unit is composed of two primary components: a GPS module and a GSM module.

The GPS module receives signals from the GPS satellites which are operated by the U.S. Department of Defense. These signals are available worldwide at every location. However, the precision of the positioning fluctuates. A thorough introduction to GPS can be found in Chapter 5.4, "Precision of the GPS-Position".

The GSM module is responsible for communication. It is a cellular module working at 850 MHz / 900 MHz / 1800 MHz / 1900 MHz. It functions properly anywhere in the world as long as GSM coverage is available.

Thus, you can use your Telic SBC3 device anywhere where you can receive network signals on your mobile phone. This means for you: You will be able to locate your vehicle pretty much anywhere in the world!

The SBC3 is dedicated for the following operating conditions:

Automated Vehicle Location – AVL

- Fleet-management
- Leasing
- Taxi / public transport

Security tracking

- Vehicles
- Precious goods

Asset tracking

- Containers
- Waggons
- Trailers

5.3 What does GPRS mean?

GPS and GPRS are two different things:

- GPS is a set of 24 satellites that send out positioning signals free of charge. These signals can be used to calculate the current position of a vehicle anywhere in the world with little technical needs.
- GPRS is a very cheap TCP/IP connection used to connect the Telic SBC3 unit to the internet. Data exchange using GPRS is much cheaper than data transmission using SMS messages.

In most cases, the billing of the connection of the device to the internet is not based on time but on data volume basis. Because the Telic SBC3 device sends very small amounts of data to the internet, many thousand statuses - and position reports can be sent to the internet for a few Euros in most countries around the world. If you want to use the GPRS interface of the Telic SBC3 unit the SIM card you are using must be enabled for using the GPRS service. Please contact the provider of your SIM card for information regarding the issue.

5.4 Precision of GPS position

The Global Positioning System (GPS) was developed in the early seventies by the U.S. Department of Defense. It is comprised of 24 satellites in various locations around the globe.



Due to the travel patterns of the satellites and their transmission technique, the precision of the data has its limits. Here we briefly present them:

A GPS receiver calculates its position by differentiating the signal from several GPS satellites. The more satellite signals it receives, the greater the precision. With a clear view of the sky, up to 12 satellite signals can be received. In order to receive a valid position, a minimum of three satellite signals are necessary. In an open field this is no problem. If the vehicle is standing still, precision of a meter or less can be achieved.

Unfortunately, we are not always presented with such an ideal terrain. In the city for instance several problems can present themselves.

For example, shading; this means, one or more satellites are blocked out by high buildings. It is then possible that signals can only be

received from some of the west, north, and south satellites, but all of the east satellites are completely blocked. This is also the case when the vehicle is stationary (or parked) close to a building.

Another source of imprecision is reflections. The signals sent out from the GPS satellites are radio signals which spread out in waves which can possibly be reflected by, for instance, large metal surfaces. Due to this reflection, the GPS module may not receive the signal directly, but rather reflected from another wall. As a result, the signal propagation delay is changed and results in a declination. In areas with high density and high buildings, this can lead to miscalculations of tens of meters!

A navigation system attempts to compensate for such problems by on the one hand, taking into account that you are moving, and on the other, by checking to see if the received GPS positions make sense compared to the route being driven (You would not turn and drive into a field 100 meters before an intersection).

A remote surveillance module cannot and should not use such tricks.

5.5 What do you need to use the SBC3?

Having the advantages of SBC3 in mind the question comes up which additional components are necessary for the operation of the device.

To use the functionality of Telic SBC3, it is essential to operate it together with a tracking service or tracking SW. If you didn't purchase the SBC3 together with such a tracking service or SW, please contact your supplier or Telic for further information, in order to be sure you are making the best use of the Telic SBC3's features and options.

5.5.1 Power supply

The remote surveillance module needs to be connected to a power source (7 volt - 36 volt direct current). It can be powered by a car battery, a rechargeable battery or a stabilized DC power supply.

5.5.2 Antennas

In order to use the device, a combined antenna or two antennas are needed:

- a GSM quad band (900 MHz / 950 MHz / 1800 MHz / 1900 MHz) antenna to communicate over the mobile network
- an antenna to receive GPS position satellite signals

The antenna offered as accessory with the Telic SBC3 device is a combined GSM/GPS quad band antenna. This makes mounting the antenna inside the vehicle as easy as possible.

Under certain circumstances it may be necessary to use special antennas. In such cases the antennas may clash with other devices with the same electrical value.

Other antennas (e.g. roof antennas) and other useful additional devices can be found on www.telic.de or on request (info@telic.de).

5.5.3 Mobile GSM Network SIM-Card

The messages of the SBC3 are transmitted via the mobile GSM network. Therefore you need a standard 3 Volts or 1.8 Volts SIM card. This can be either a prepaid or a post paid SIM card.

5.5.4 Please give preference to post paid SIM cards!!

Prepaid SIM cards have the advantage that they don't produce fixed costs but they have the disadvantage that the credit of the prepaid SIM-card will eventually be exhausted. The SBC3 will not be able to send anymore status messages if there is no credit on the SIM card. To avoid this case we don't recommend using prepaid SIM cards, since the device would be rendered useless in the situation were all the credit on the SIM is used up.

5.6 Operation set-up

The remote surveillance module can be installed into your vehicle using the following six steps:

5.6.1 First Step: Open the Device



Please open the SBC3 housing by unscrewing the 4 Phillips housing screws.

The SIM card holder can be found under the top cover.

5.6.2 Second Step: Insert the SIM card

Before the SBC3 logs into the mobile GSM network, it checks whether the used SIM card is PIN free. If it is PIN free, it will start normal operation.

If the SIM card is not PIN free, it has to be assured that the PIN is set to "0000", "2468" or "1111" before it has been inserted. The PIN can be changed e.g. with a standard GSM mobile phone to "0000", "2468" or "1111".

To speed up the log-in process into the GSM network, the SIM card should contain no or only a few phone book entries.

The insertion of the SIM card into the SBC3 is easy:

- Place the device in front of you on the desk such that the external connectors are facing away from you.
- Slide the SIM card cover carefully away from yourself towards the direction of the arrow between the two words "OPEN"



- carefully flip the card reader sideways then up (see picture)



- Now insert the SIM card into the SIM card holder so that the cut corner matches with the corresponding marking on the SIM card holder. Do not touch the contacts of the SIM card. If necessary clean the contacts with a soft cloth.
- When inserted correctly the gold contacts of the SIM card should be facing down.
- Flip the SIM card holder back into its original position and slide the lock back towards your body
- If you cannot close the SIM card holder, you may have inserted the SIM card in the wrong direction

With this step you have finished the SIM card installation

5.6.3 Switching the device on and off

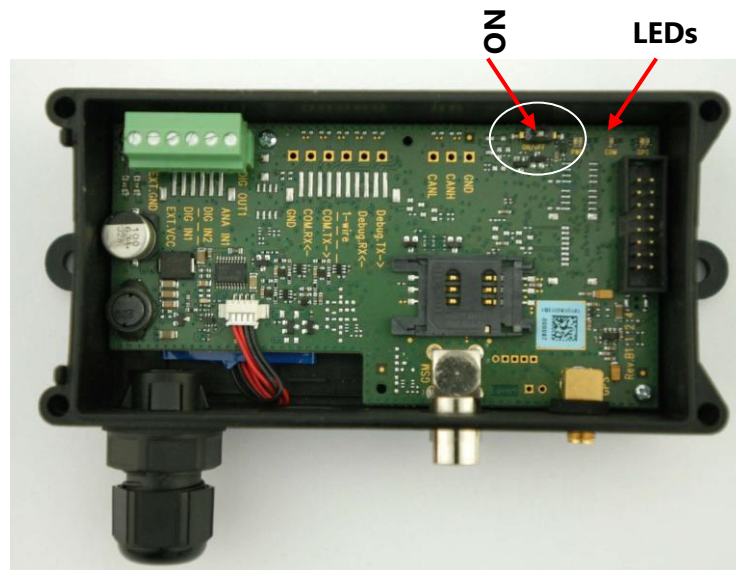

Normally the device is delivered by Telic with the power switch being switched to the "OFF" position.

If the Telic SBC3 remote control unit is switched off, you can switch it on by moving the switch marked with ON with a non metallic tool (e.g. a toothpick) into the position marked with "ON". You can find the switch below the SIM card near the edge of the device.

If you want to switch the device off, then please move the switch marked with ON with a non metallic tool (e.g. a toothpick) from position "ON" into the other position.

5.6.4 Third Step: Close the Cover

Please close the SBC3 housing by screwing the 4 Phillips screws down back into its original position. The clear plastic light guides must be located above the LEDs. Please ensure that the cover locks properly into position.

Min torque M = 1,2 Nm max. Torque M = 1,5 Nm



5.6.5 Fourth Step: Connecting the antennas

The device is equipped with connectors for a cellular network antenna (GSM antenna) and a satellite antenna (GPS antenna).

Please connect now the two antennas according to the picture below. You cannot interchange the two antennas because they have different connectors.



Connector for GSM-antenna

Connector for the GPS-antenna

5.6.6 Fifth Step: Connecting the unit to the vehicle

Please connect the Telic SBC3 remote control unit to the vehicle according to the following instructions using the connection cable which can be bought as accessory part.

Please do not connect the connector to the Telic SBC3 remote control unit before all cables you intent to use are connected to the vehicle in order to prevent a shortcut.

5.6.6.1 Power Supply

Depending on the intended mode of usage, you can connect the device to the power supply in two different ways:

5.6.6.1.1 The device must stay active after ignition off

This operating mode has the disadvantage that the device continues to consume power while the ignition is off. This means that the battery of the vehicle can eventually run out of energy. A discharged battery could result in the vehicle not being able to start its engine after a few days without operation (depending on the size, age and charge level of the battery).

The advantage of this operating mode is that the device is able to connect faster to the GSM network and it can find faster a new GPS position after ignition was switched from "OFF" to "ON". This means that for example working time calculations will be more precise.

If the Telic SBC3 remote control unit is configured not to use the power save feature, then the device can detect and report in this mode that it is moving (e.g. if it is stolen or while a construction machine is transported on a truck) even while ignition is off.

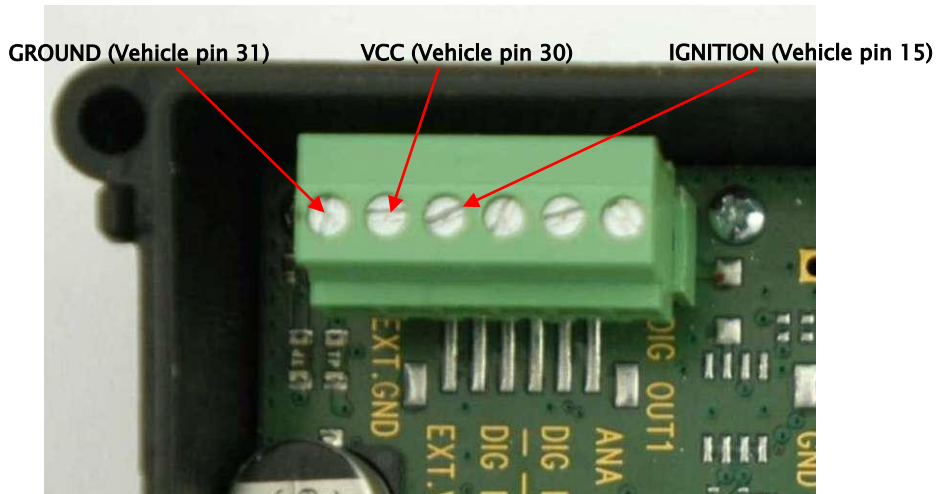

To operate the Telic SBC3 remote control unit in this mode the grey **and** yellow wires must be connected to the GROUND (pin 31 of the vehicle) and the pink wire must be connected to VCC (pin 30 of the vehicle).

The green wire must be connected to ignition (pin 15 of the vehicle) in this mode.

5.6.6.1.2 The device must be switched off when ignition is switched off

This operating mode has the advantage, that the device does not consume any power while the ignition is off. This means, that the battery of the vehicle cannot run out of energy which means, that the vehicle will always be able to start its engine even after a few days without operation.

You can configure how long the SBC3 should stay awake. Furthermore you can configure the input which arouses the SBC3 again.

The disadvantage of this operating mode is that it takes the device longer to connect to the GSM network and it takes longer to find a new GPS position after ignition was switched from "OFF" to "ON". This means that for example working time calculations will be less precise.

In addition it can happen in this operating mode that short trips are not registered at all.

If the Telic SBC3 remote control unit is configured not to use the power save feature then the device can detect and report in this mode that it is moving (e.g. if it is stolen or while a construction

machine is transported on a truck) even while ignition is off, but only as long as the internal backup battery can provide enough energy (typically a few hours)

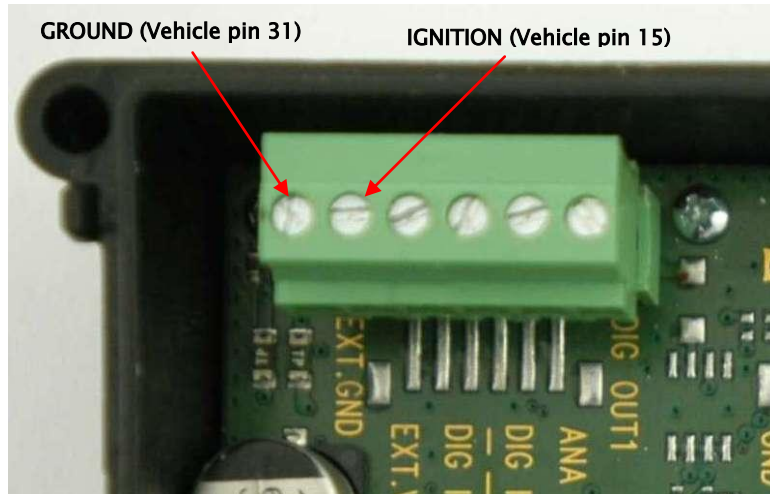

To operate the Telic SBC3 remote control unit in this mode the grey **and** yellow wires must be connected to GROUND (pin 31 of the vehicle), and the pink **and** green wires must be connected to IGNITION (pin 15 of the vehicle).

If you connect the device according to the above mentioned scheme to the cigarette lighter and even if the cigarette lighter is switched on and off together with the IGNITION (which is the case in most vehicles) the routes driven by the vehicle will be reported correctly.

5.6.6.1.3 Fuses

The device contains internal fuses to protect it against >60 V high voltage and wrong connection to the vehicle.

These fuses cannot be changed by the user. So please pay attention while installing the device.

If you think the fuses are damaged (which rarely occurs in a 12 volt / 24 volt vehicle) please contact your supplier.

5.6.6.2 Digital inputs

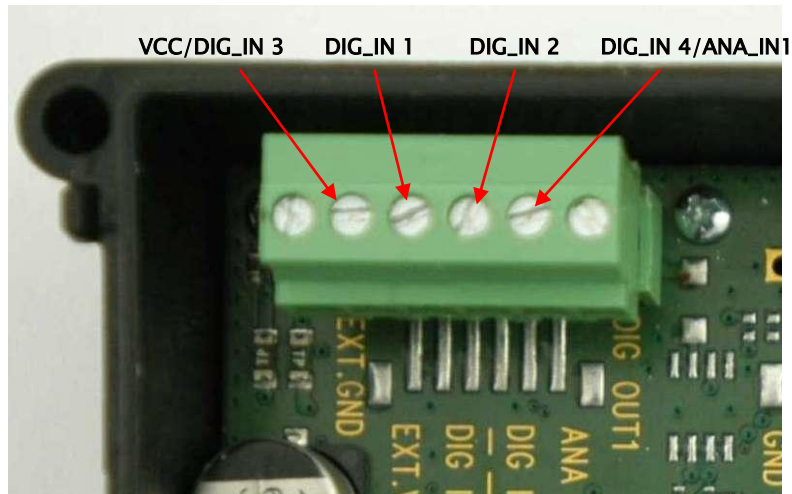

The digital inputs can be connected to any signal which reports "ON" or "OFF". The inputs can be used with a voltage up to 36 volt.

- Voltages between 0 volt and 1 volt are detected as "low"
- Voltages between 7 and 36 volt are detected as "high"

5.6.6.3 Digital output

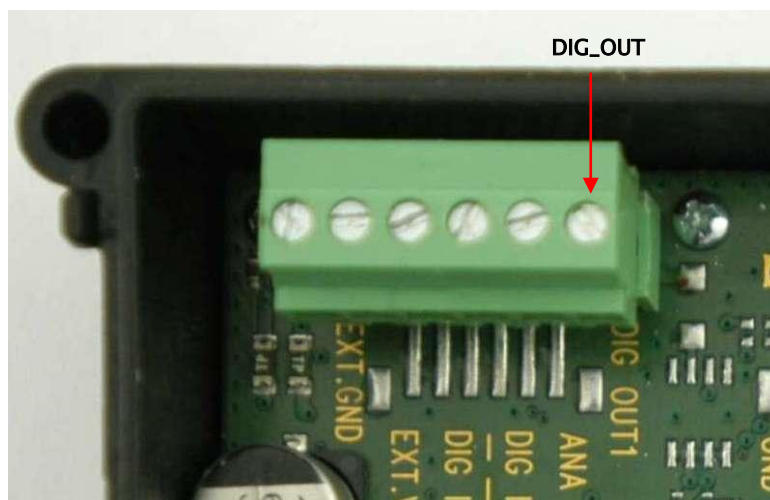

The digital output can be switched with an SMS command or with a GPRS command (chapter 9.1 Switch of the digital output).

Outputs are low side switches. If active they will make a connection to GND. If not active it is high impedance. A current of max. 1A can be drawn.

5.6.6.4 Wiring description of the connector

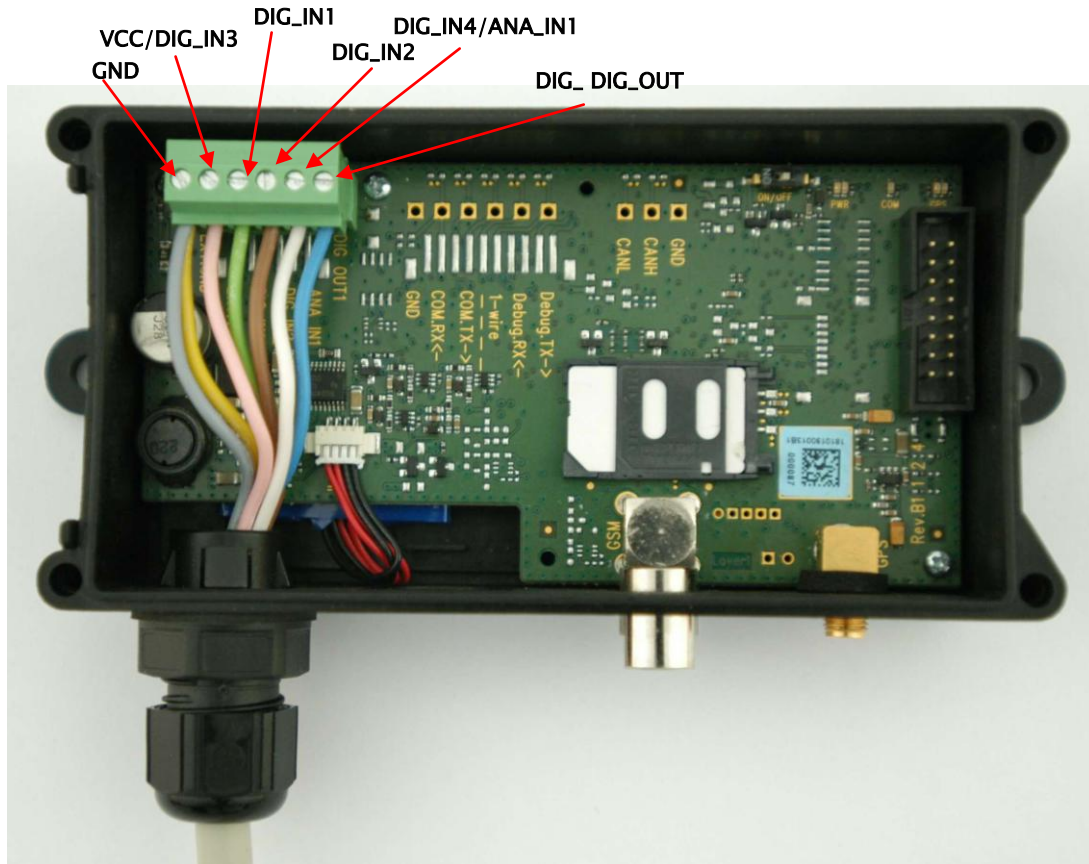

Signal	Cable Colour
VCC / DIG_IN3	Pink
GND	Grey and Yellow
DIG_IN1	Green
DIG_IN2	Brown
DIG_IN4 / ANA_IN1	White
DIG_Out1	Blue

If you do not use some of the wires of the connector then please ensure, that these wires cannot accidentally contact any metal parts of the vehicle.

5.6.7 Sixth Step: Install the Remote Surveillance Module

In order to protect your vehicle from theft and vandalism the device should be installed in a location where the device, its antennas, and its power supply are well-hidden and where it is easy at the same time to switch the main switch of the device (located below the SIM card holder) on and off.

Using the corresponding two screws and holes in the device, please install the device in a suitable, dry location.

When installing the antennas, please be aware that the antennas must have a free view to the sky (not blocked by metal or liquids) in order to receive good signals.

The antenna should have a minimum distance of 7 cm to metallic components of the vehicle in each direction.

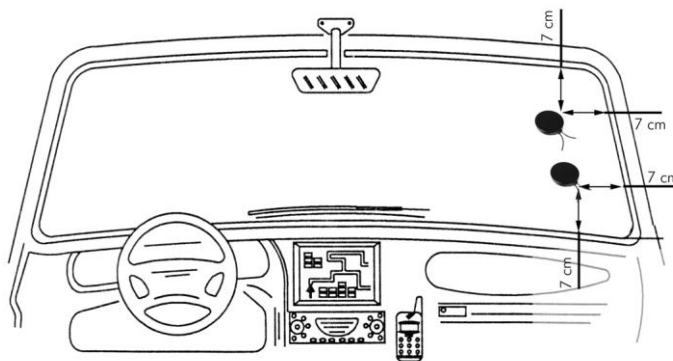

The combined GSM/GPS antenna (accessory part) is only intended to be mounted inside the vehicle because the antenna cannot withstand wet environments.

Other types of antennas (e.g. roof antennas) are available. Please contact your supplier of the device.

A perfect place for the combined GSM/GPS window antenna is inside the vehicle glued to the windshield with the adhesive side of the antenna under the white protection paper. Please clean the window with alcohol or a similar product and then remove the white paper in order to fix the antenna at the desired place.



If you choose another place for the antenna please ensure that the side of the antenna with the white paper points towards the sky. This is important because this side of the antenna is the active one.

Attention:

A buckled or furled cable can (even if its isolation is not damaged) reduce the quality of the received signal significantly.

Please also be aware that metallised windshields can also strongly interfere with the signals of the GPS satellites causing poor reception of the GPS position signals.

In addition the antenna should not be mounted behind the OFF position of the windscreen wiper.

6 The tracking via a tracking program or tracking server

Using the Telic SBC3 remote control unit in conjunction with a tracking program or a tracking server is recommended for efficient results.

For the set-up of the Telic SBC3 remote control unit, the Telic SBC3 has to be configured with the necessary data. For this purpose a configuration-SMS (Short Message) has to be sent to the device, which includes the operation relevant parameters (e.g. the IP address of the server, to which the tracking data have to be sent). Alternatively to that the configuration parameters can also be set up via the serial interface.

More information regarding configuration commands can be found in the Software Protocol Specification.

After the configuration of the relevant parameters status messages will be generated and will be sent via GPRS. Together with them, also the GPS-position and the status of the digital inputs and output will be additionally sent. More details regarding this can be found in chapter 13 "The status message"

7 General functionality of Telic SBC3

The Telic SBC3's primary task is to communicate GPS position data with additional status information via an existing TCP/IP connection as status messages.

If a message can't be communicated, it is stored in the device and will be sent later on. A minimum of 1000 position messages can be stored.

The following events will create a position message:

- The end of a time period of x seconds*.
- After a distance of x meters (straight line distance to the previous event) in any direction has been travelled.*
- A direction change of a configurable minimum angle in x degrees at a configurable minimum speed of y km/h.*
- Changes of the status of the digital inputs
- Cut off and re-connect to the main power supply

*x and y being configurable

After the switching on of the Telic SBC3 remote control unit at the beginning the GSM module as well as the GPS module will be internally powered up.

As soon as the GSM module has successfully logged into the GSM network all currently available GSM networks are recorded which allow the use of GPRS with the SIM card inserted into the device.

Finally a TCP/IP connection to the tracking server will be established.

The selection of the GPRS provider takes approx. 1 minute as well as the log in process into the control centre software. This means, that it will take approximately 2-3 minutes after switching the device on until the first status report can be sent to the control centre.

Independent of this delay the first GPS positions will be recorded and will be stored as status reports inside the device until they can be sent to the control centre.

The first identified and valid GPS position will be taken as the reference position for the distance interval calculations. The next distance interval event will be generated if the configured distance has been reached.

In the case of a direction change being greater than the configured angle while travelling at the configured minimum speed a position message will also be generated.

Changes of a digital input causes the transmission of a status report. If no actual GPS position is available the last known GPS position will be transmitted.

Each new status report sets a new reference point for distance calculations.

8 The digital inputs

The Telic SBC3 remote control unit puts at your disposal 2 digital inputs as default.

To detect a signal as "high" (logical 1) a voltage between 7 volts and 36 volts has to be put. The input will be recognized as "low" (logical 0), if a voltage between 0 volts and 1 volt is put to the digital input. For each change of the digital input a status message incl. the latest valid GPS position will be sent to the control centre.

9 The digital output

A change of the digital outputs can be made via GPRS from a server.

The Digital output is open collector, sending a high ties the output to ground, a "Low" leaves the output open

A change of the digital output via SMS is also possible (in 7-Bit text format, as usual in a regular GSM-Mobile network device).

9.1 Switching the digital output

The digital outputs can be switched via GPRS or SMS. The related message is as follows:

EG: 004000886611

With this SMS the digital outputs are pulled to low.

The message is composed of:

00 – Message-ID (free choice between 00 and 99)

40 – Code setting of the output

008866 – the last 6 numbers of the labelled IMEI number of the device.

x – Mask for change of the digital output 1, x: DOUT1

More details are described in the Software Protocol Specification.

9.2 Automatic answer of the digital output

If it has to be ensured that the output has been set and respectively re-set correctly, there can be requested an acknowledgement from the remote control unit.

This can be done via the Codes 41.

Example: 004100886611 to be sent via SMS or GPRS

Reply:

0044008866TSTANDARDDBC30019,1,359563000008668,24100611425
9,115872,480334,3,0,340,,,,,0,,1,00,223,217

This reply is transmitted using the "return to sender" principle, which means a request via SMS will be transmitted via SMS, a request via GPRS via GPRS.

10 The analog input (ANA_IN1)

The analog input of the Telic SBC3 remote control unit can be used to reflect the actual status of the voltage supply of the Telic SBC3 remote control unit.

Within the transmitted data a numeric value is indicated being between 0 and 255.

10.1 Boardnet-voltage (analog input VCC)

The value of the analog Input 1 can be used to represent the voltage value of the board net. A single digit is the equivalent of 128mV + offset 6,0V. To measure the boardnet voltage, wire 0.27 has to be connected to VCC.

10.2 Battery-voltage (analog input battery)

The value of the analog input 2 represents the voltage value of the internal battery. 1 digit is the equivalent of 19,8mV.

11 Additional Features of SBC3 CAN

11.1 Serial interface

The Telic SBC3 remote control unit provides a serial interface.

This interface can be used for the following purposes:

- Access to external end devices like displays or other in-/ output devices
- To read out status information while handling the SBC3 (trace files)

11.2 CAN interface

The Telic SBC3 remote control unit provides a CAN interface to collect data directly from the vehicle.

It is important to remember when using the CAN interface it must be properly terminated.

Please get into contact with Telic GmbH to define your operating condition for this interface.

11.3 1-Wire interface

The Telic SBC3 remote control unit provides a 1-Wire interface.

Please get into contact with Telic GmbH, to define your operating condition for this interface.

11.4 SBC3-CAN wiring description

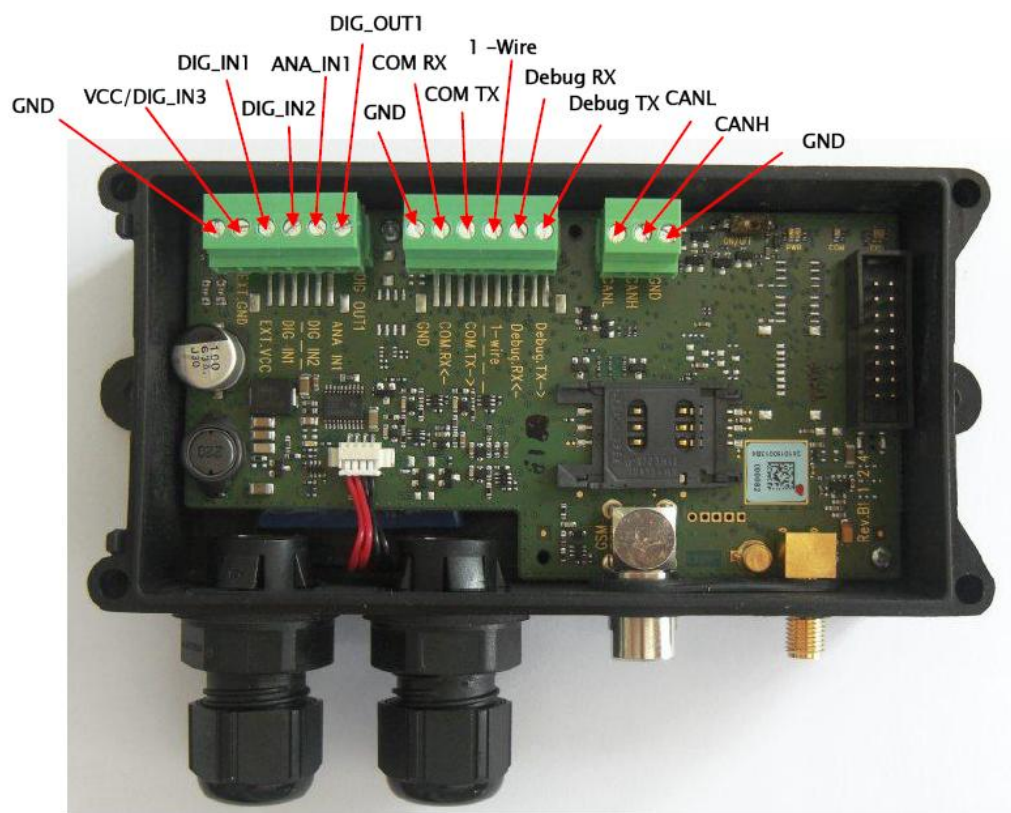

Connector on the left:

Signal	Description
GND	Ground
VCC / DIG_IN3	External power supply 0 – 32V DC (optional digital input)
DIG_IN1	digital input 0 – 32V / DC
DIG_IN2	digital input 0 – 32V / DC
DIG_IN4 / ANA_IN1	analog input 0 – 30V / DC
DIG_Out1	Low side switch, max. 1A

Connector in the middle:

Signal	Description
GND	serial ground
COM RX	interface for external serial device V24 level -12V ... +12V
COM TX	interface for external serial device V24 level -12V ... +12V
1-wire	interface for external 1-wire devices 3,3V / DC
Debug RX	serial interface for Telic-Traces V24 level -12V ... +12V
Debug TX	serial interface for Telic-Traces V24 level -12V ... +12V

Connector on the right:

Signal	Description
CAN_L	bus signal CAN low
CAN_H	bus signal CAN high
GND	CAN ground

supported CAN protocol: SAE J1939

12 Other features

12.1 Testing the device

After the installation of the device inside the vehicle we strongly recommend to verify the proper installation as follows:

12.1.1 Verification by the LEDs



The device has three LEDs. The blinking patterns of these LEDs can give you valuable information about the proper function of the device:

Assigned indicator	Meaning								
POWER	<p>The left indicator consists of a green and a red one.</p> <p>The green LED will be permanently on, when the Telic SBC3 has external power supply and the battery is full charged. While charging the battery, the indicator is red.</p> <p>Please note: If it is off, this does not mean, that the Telic SBC3 remote control unit has been switched off. Instead, if this LED is off, this means, that the device currently does not receive any power from an external power source.</p>								
COM	<p>The yellow LED reflects the GSM status and also, whether the device is switched on.</p> <table border="0"> <tr> <td data-bbox="499 1218 730 1256">off</td> <td data-bbox="738 1218 1347 1256">the GSM module is not switched on</td> </tr> <tr> <td data-bbox="499 1272 730 1310">Permanently on</td> <td data-bbox="738 1272 1347 1346">GSM is switched on, but no GSM networks available.</td> </tr> <tr> <td data-bbox="499 1391 730 1429">Blinking once</td> <td data-bbox="738 1391 1347 1464">device is logged into the GSM network, no connection to server</td> </tr> <tr> <td data-bbox="499 1509 730 1547">Blinking twice</td> <td data-bbox="738 1509 1347 1621">device is logged into GSM network, GPRS is attached, established TCP/IP connection to server</td> </tr> </table>	off	the GSM module is not switched on	Permanently on	GSM is switched on, but no GSM networks available.	Blinking once	device is logged into the GSM network, no connection to server	Blinking twice	device is logged into GSM network, GPRS is attached, established TCP/IP connection to server
off	the GSM module is not switched on								
Permanently on	GSM is switched on, but no GSM networks available.								
Blinking once	device is logged into the GSM network, no connection to server								
Blinking twice	device is logged into GSM network, GPRS is attached, established TCP/IP connection to server								

12.2 Data buffering in case of bad GSM network

In areas of weak or nonexistent GSM network the device buffers the data meant for transmission in its internal data memory until GSM coverage is available.

This data memory stores the data even if the power supply of the device is temporarily interrupted. The data memory is capable of storing approx. 1000 status messages.

If further data needs to be stored, even though the data memory is already entirely used, the oldest data set will be erased and replaced by the new one.

The data will be sent to the control server as soon as the connection to a mobile phone network can be re-established. The oldest status report will be sent first.

While sending previously recorded status reports, newly generated status reports will be sent immediately which means that sending the older status reports will be interrupted for a short while.

12.3 Automatic switch off of the Telic SBC3

If the external power supply of Telic SBC3 is interrupted (e.g. if the power supply is controlled by the ignition) and if consequently the charge in the internal battery is exhausted, the SBC3 remote control unit switches off automatically.

Even though in this status there is no external power supply anymore, all relevant operation parameters, the configuration settings as well as the content of the data buffer remain stored.

By reconnecting the external power supply (e.g. ignition on), the Telic SBC3 is switched on again.

12.4 The integrated Watchdogs

The SBC3 has different integrated watchdogs. They automatically check the functions of the device and generate resets as soon as they recognise any malfunction.

Malfunction could occur due to internal problems of the device, problems related to the GSM connection, problems with the GPS reception, etc.

Due to this watchdog it is assured that the SBC3 is able to return automatically to stable operation if necessary.

Control of the watchdogs by the user is not necessary.

If the watchdog has to restart the device it may happen that some of the position messages and respectively events are not logged and as a result are not transmitted to the tracking server.

13 The status message

Status messages are data sets being generated due to different event types. Status messages will be sent immediately after they occur out of the database if previously stored.

You can define the way the messages are transmitted to the control centre for every single status message. You can select between transmission via GPRS, transmission via SMS or transmission via GPRS **and** SMS.

Independent of the current configuration all messages are transmitted via SMS if there is no GPRS connection possible (e.g. congestion of the network or a bad GPRS network coverage). In this way it is sure that almost every message is transmitted to the control centre in time.

The event mask provides the opportunity to enlarge the status message with some more information which is not necessary for the normal use. You can read out quality of the GPS-signal, MSC (Message Code: recognition of the country) or MNC (Mobile network code: to identify the network provider). This is meant for security scenarios, to receive more information about location and status of the device.

13.1 Content of a status message

Content	Description
Event/Log - Code	Reason for the status message
Event/Log Timestamp	Time when the event was triggered

Content	Description
GPS Timestamp	GPS timestamp at the moment of fetching longitude and latitude
Longitude	Degree of longitude in 100 μ degrees
Latitude	Degree of latitude in 100 μ degrees
Fix Type	1,2 or 3, depending on the availability of satellites in view having a sufficient signal strength: 1D Fix (no valid data) 2D Fix (no height indication) 3D Fix (position message with height indication)
Speed over ground	Speed in km/h
Course over ground	Direction in degrees
Sats for calculation	Actual number of satellites which are used for calculation
Height	Height above sea level (in m)
Mileage	Milage in km
DigIns	4 digits e.g. 0010, if DigIn3 = High (Ignition on)

13.1.1 Event and Log Codes

This code indicates which event has triggered the status message. For further information please refer to the Telic Protocol Specification.

Code	Description
1	Start-Up Event will be sent immediately after the switch-on (e.g. via ignition on) Includes the last stored GPS position, being usually generated during "ignition off".

Code	Description
6	Direction Change Event Example: - Minimum speed: 6 km/h - Minimum change of direction: 30 degrees
11	Digital Input 1 changed from "low" to "high"
12	Digital Input 1 changed from "high" to "low"
13	Digital Input 2 changed from "low" to "high"
14	Digital Input 2 changed from "high" to "low"
15	Digital Input 3 changed from "low" to "high" (Connected to external power supply)
16	Digital Input 3 changed from "high" to "low" (no external power supply is connected)
17	Digital Input 4 changed from "low" to "high"
18	Digital Input 4 changed from "high" to "low"
30	Incoming Call Event - SBC3 sends an event message when the device is being contacted via voice call.
98	Configurable distance (in a straight line) has been travelled since the last creation of a status message
99	Configurable time period in seconds is elapsed and a related message is created

13.1.2 Mileage counter (in meters)

In the device a mileage counter is implemented. This mileage counter adds the covered distance and provides this value in meters. The calculations are made based on GPS information. This can lead to deviations of up to 5%. At low speeds (e.g. parking, traffic jam, etc.) the deviation can be higher.

All information generated by the mileage counter is analysed by the control centre and can be used e.g. for a driver's log.

It is possible to initialise the mileage counter in the device. This is useful when you mount the device into a vehicle that already has an odometer reading other than zero and the user wishes to align the SBC3 odometer with the vehicles.

The mileage is a part of the basic configuration and can be adjusted via SMS or GPRS. Please be aware, that the numeric value has to be put in meters. So the mileage of 83213 km has to be put as 83213000.

13.2 Sending strategies for status messages

13.2.1 Distance based status messages

One of the most significant tasks of the device is tracing routes. For this purpose the GPS information of the status messages is recommended.

The device sends the event including GPS position, when it has travelled a distance greater than the configured distance.

Usually it will get significantly shorter with the functionality being described in the chapter 13.2.2 "Direction change based status messages".

When these two methods are used in combination a typical cross country route will function as follows:

Position messages will happen more often at the beginning of a route (e.g. leaving an industrial or residential area).

On the highway position messages will be relatively seldom, as the route is straight forward.

In the target area (after leaving the highway onwards) the number of position messages will then again increase due to entering in industrial or residential areas with frequent direction changes.

13.2.2 Direction change based status messages

The device will send a status message with position information when the driving direction has changed compared to the previously generated position by more than x degrees.

In the device an angle is configured, so that a turning will always be recognized. This function can also be switched off using an event mask or another angle can be chosen. Please contact your supplier if changes are required.

13.2.3 Status messages for certain events

The Telic SBC3 tracking and tracing module sends status messages for the following events:

Event	Description
Change in state of a digital input	The SBC3 sends a status message always if a status of any input has be changed.
Connection and disconnection of the external power supply	The SBC3 sends a status message as soon as the external Power supply be connected or disconnected (e.g. ignition on / off).

13.2.4 The speed filter

The Telic SBC3 has an integrated speed filter for direction dependant status messages (see also chapter 13.2.2 "Direction change based status messages").

This filter prevents the sending of direction dependant status messages when the speed of the vehicle is lower than the configured value.

The advantage of this filter is that for example, if a digger is in action on a building site and is steadily turning around itself these turning movements won't be transmitted to the tracking server. However if the digger is being transported to another site, all direction changes will precisely be taken into account, so that the real route the digger made can be verified later.

The higher the speed threshold is configured the longer it will take for the device to report a change in direction in some circumstances. This is because often the vehicle slows down while turning and until it accelerates above the threshold the new direction will not be recognized.

13.3 Hints for some special situations

13.3.1 First position of a new route

The first position of a new route is always identical to the last position of the former route. If the device at the end of a route is switched off and is switched on again later at another site, the last

position stored in the logbook (of the former route) will show up as the first position of the new route with the respective errors in the odometer reading.

Therefore it is not recommended to switch off the device during transport from one site to another.

13.3.2 Last position of a new route

As soon as the ignition is switched off the actual position is logged in the non-volatile memory.

When starting-up the device the last ignition-off position will be read out of the memory and, once the clock is set, will be sent as an ignition-on position event. Nevertheless the clock can be set at the earliest when the GPS data includes a time stamp. So it might occur that the ignition-on position event will be sent with a delay, especially when the GPS receiver has to readjust itself after being disconnected from the power supply.

14 Geofence

Geofence (an electronic safety fence) provides the opportunity to set a geographic square around a defined location.

Here you can set different scenarios like "leaving the area" or "entering the area" and transmit an event to the control centre.



With the SBC3 you can monitor 50 geofence areas which can also be combined to create larger areas and build up a complex protection zone.

14.1 Position Lock Alarm

With the Position Lock Alarm you can monitor if the device leaves the actual position with a predefined periphery. The actual position is stored automatically if the ignition is turned off. If the SBC3 then leaves the defined square (e.g. a car theft) an alarm event will be generated and transmitted to the control centre.

Applications example:

A construction machine needs to be secured against burglary. The SBC3 has to be connected via car power cable to the ignition of the

vehicle. After deactivating the engine (and ignition) the actual position is stored. If the construction machine is abstracted (e.g by a adherer) out of the periphery, the SBC3 sends an alarm message.

For this operating condition, the SBC3 has to be always activated.

15 Quickstart

15.1 Hardware installation

Check activation of the SIM - card including GPRS option.

Deactivate the using PIN of the SIM card using a cell phone, or change it to "0000" , "2468" or "1111".

Open the cover to put the SIM card into the device.

Please pay attention to observe ESD (Electro Static Discharge) protection measures.

Switch device with power on switch to "ON"

After inserting the card and power "ON" the device please close the Cover again.

Mount the device in the vehicle.

Connect the combined antenna (the antenna should have free view to the sky).

Connect power supply and ignition:

- Wires pink and green at ignition (vehicle pin 15)
- Wires grey and yellow to GROUND (vehicle pin 31)

Connect the connector to the device

15.2 Quick test

Put the vehicle in an area where the tracking and tracing module has good GPS and GSM reception (free view of the sky in all directions). You can identify a good GPS signal when the GPS LED is blinking green three times.

Please make sure you have good GSM reception. This is indicated by a slow once (or twice) blinking of the green LED in the left indicator.

16 Request and change of configuration

The Telic SBC3 gets requests for actual configuration resp. configuration changes either via SMS or via a TCP/IP connection per GPRS.

Sending an SMS to the device and having chosen the option with acknowledgement, this acknowledgement will be sent back to the sender of the original SMS.

Please contact your device supplier in case of need.

16.1 SIM card and provider specific parameters

16.1.1 PIN-Code of SIM card

The PIN of the SIM card will be assumed to be "0000", "2468" or "1111". Also an operation of SIM cards with deactivated PIN is possible.

16.1.2 GPRS Parameter

The GPRS relevant parameters APN, user name and password have to be configured based on the information from the GSM network provider.

If you use a SIM card from another GSM network provider, you have to set up the new GPRS parameters using the configuration commands or configuration file.

For more information please get in contact with your supplier.

The SBC3 provides the opportunity to use preset SIM- and provider lists for each SIM card.

Please note that APN-Settings in the provider list (if used) have a higher priority than the general default APN setting.

16.2 Systemspecific paramters

The device has following default configuration:

Parameter	Default Value
Distance between two waypoints	5000 m
GPS kilometer counter	0 m
GPRS Reconnect delay	80s
Server IP address	0.0.0.0
GPRS IP-Port	0
Distance between two position events	5000 m
Direction Event	30 degrees and a minimum speed of 6 km/h
Acknowledge Mode	disabled With this configuration the amount of data to be transmitted per status report will be approx. 1/3 higher. On the other side this configuration ensures, that no data will be lost during its transmission from the Telic SBC3 remote control unit to the control centre.

17 Error handling

There are a number of error sources, which can prevent the proper operation of the Telic SBC3 remote control unit.

This chapter can be used to help you detect and avoid the most common sources of errors and problems.

Possible malfunctions:

The device doesn't show any sign of life

Possible error source	Trouble shooting
The ON/1 switch is set to 1	<i>Switch on the ON/1 switch located besides the SIM card by sliding it to ON.</i>
The unit is not connected correctly to your vehicle	<i>Please connect the unit to the vehicle according to the scheme in this manual</i>
On-board power supply failure or defective internal fuse	<i>You cannot fix this problem yourself. These fuses should protect the device and the periphery and only get damaged by extensive surcharge. You have to send the device to Telic or to your supplier.</i>

The device cannot connect to a GSM network

Possible error source	Trouble shooting
The Telic SBC3 isn't in a GSM covered area.	<i>Please check whether there is GSM reception in this area (e.g. using a cell phone) and move eventually to another area.</i>
The GSM antenna is not properly attached or the antenna cable is defective	<i>Check to see if GSM antenna is properly attached and if the cable of the antenna is damaged.</i>
The SIM card in the SBC3 is new and has not yet been activated	<i>Please check, whether the SIM card is already activated. This can be done e.g. by putting the SIM card in your cell phone and checking whether or not your cell phone is able</i>

Possible error source	Trouble shooting
	<i>to log into a GSM network.</i>
The SIM card has been locked by the provider.	<p><i>Please check whether the SIM card is locked.</i></p> <p><i>This can be done e.g. by putting the SIM card into your cell phone and checking whether your cell phone is able to log into a GSM network.</i></p> <p><i>Is this not the case, than please try to make a phone call. If you are successful, the SIM card is definitely not locked.</i></p>
The prepaid bonus is exhausted.	<i>Please recharge the SIM card being in the tracking and tracing module.</i>
The prepaid SIM card is no longer valid .	<p><i>Prepaid SIM cards will loose their validity, if they aren't topped up on a regular base (often after 12 or 24 months).</i></p> <p><i>In this case usually you have to buy a new SIM card.</i></p>
<p>The PIN code of the card hasn't been deactivated</p> <p>respectively</p> <p>The PIN on the SIM card is not corresponding to "0000", "2468" or "1111".</p>	<p><i>Please remove the SIM card from the device and check the PIN code.</i></p> <p><i>The PIN code has to be deactivated or has to be set to "0000", "2468" or "1111".</i></p> <p><i>After a triple wrong entry of the PIN, the deblocking of the SIM card requires the PUK.</i></p>
The SIM card hasn't been inserted into the SIM card holder in the correct way	<i>Please check the correct position of the SIM card in the card holder.</i>

The device doesn't log into the GPRS network

Possible error source	Trouble shooting
-----------------------	------------------

Possible error source	Trouble shooting
The GPRS service is not yet activated.	<i>Please ask your provider, whether the GPRS function is already activated for the SIM card in use.</i>

The device doesn't receive GPS data

Possible error source	Trouble shooting
The GPS antenna is not connected	<i>Please correct the GPS antenna according the picture in this manual.</i>
The GPS antenna has no free sight to the sky.	<i>Please be aware, that a GPS antenna needs always clear view to the sky. In this case, the GPS antenna must be mounted outside the vehicle (e.g. on the roof) or behind the windows in the front of the car (which sometimes have no metal layer even if the front window has a metal layer).</i>
Your vehicle is placed in an unsuitable place.	<i>Please consider that a GPS reception is only possible in case of free sight between the GPS receiver and the sky. Please put your car for the test to a more suitable place (no buildings nearby, outside of a garage / factory a.s.o.)</i>

Further hints regarding sources of error are indicated through the 3 LEDs of the 3 indicators, which are easily visible from outside.

Details for the meaning of the different colours and blinking signs you will find in chapter 12.1.1. "Verification based on the LED indications".

18 Power consumption

If your vehicle isn't used for a couple of days and the device is correctly connected, we recommend disconnecting the Telic SBC3 from the board net (by the ignition signal)

If the ignition is switched off the SBC3 will send a status message to the control centre and stays operable for a defined time due to the internal LiPolymer battery. Hence the further operation may not discharge the car battery. By activating the ignition, the SBC3 is switched on again and has its normal operating condition. While the power supply is connected, the internal battery is charged.

19 Technical data

Components	Description
Dimensions	145 mm(B) x 100 mm (L) x 40 mm(H)
Connectors	- 1 FME male antenna connector for GSM - 1 SMA female antenna connector for GPS - I/O connector / Power
LEDs	3 Status - LEDs to indicate the status of COM, GPS, POWER
GSM/GPRS Modul	Quadband-GSM-Modul
GPS Module	50 channel GPS receiver
Backup battery	660mAh Lithium Polymer, 3,7 V
Operating Temperature	-30°C ~ +75°C For the charging of the internal battery the temperature range should be between 0°C and +45°C to prevent battery aging.
Supply voltage	7V - 36V DC
Housing	Black water resistant housing
Certificates	-ROHS- conformance -E-Marking -This device complies with part 15 of the FCC Rules. Operation is subject to the following two conditions: (1) This device may not cause harmful interference, and (2) this device must accept any interference received, including interference that may cause undesired operation.

20 Accessories

Telic GmbH offers accessories for SBC3 which have been thoroughly tested and approved. Therefore we recommend using only accessories from Telic. Warranty claims can only be accepted if the SBC3 has been used with original Telic accessories.

Please contact your supplier or Telic GmbH for further information on original accessories for the SBC3; recommended parts are

Combined GSM/GPS antenna- Part-Nr. 16004
Cable antenna with adhesive stripes for inside window ca. 5m cable (This antenna belongs to the standard delivery content)



SBC3 – Cable – Part-Nr. 16300
7 wires



Waterproof GSM-roof screw antenna - Part-Nr. 12006-
FME-Connector, 3m cable



GPS-antenna - Part-Nr. 16002
cable antenna with a magnet, ca. 3m Cable



GSM- antenna with magnet – Part-Nr. 12001-
FME –connector and 2,5m cable



GSM-angle antenna - Part-Nr. 12011-
FME- connector, 90°, Quadband-Version



21 Document history

Revision	Date	Changes
Rev 1.00	25.10.2010	Release
Rev 1.10	26.01.2011	Update housing info
Rev 1.2	28.04.2011	Include FCC information
Rev 1.3	15.07.2011	Change output current of Digital IO, minor corrections

Telic GmbH
Raiffeisenallee 12b
D-82041 Oberhaching
Deutschland

www.telic.de

Note: Specification is subject to change without prior notice. No responsibility is taken for the correctness of this information.