

## Telic STD35



### User Manual

### Version 1.4

1	Introduction .....	3
1.1	Attention, please read this.....	4
2	Background Information .....	5
2.1	GSM-Network in general.....	5
2.2	GPRS.....	5
2.3	Quad band Frequencies.....	5
2.4	Internet in general .....	5
2.5	E-mail via SMTP .....	5
2.6	Web Server .....	6
2.7	Fixed IP.....	6
3	Operating Conditions .....	6
4	Proper Use .....	7
5	Introduction .....	7
6	Quick start-up.....	9
6.1	General preparations .....	9
6.2	Hardware preparations.....	9
6.3	Configuration Call.....	9
6.4	Quick configuration check .....	10
7	SMS Commands .....	10
7.1	Table of SMS command.....	11
7.2	Variable substitution.....	14
Send SMS Commands.....		14
A configuration command should look like the following example:.....		15
7.3	Explanation of the commands.....	15
7.4	Examples for SMS Commands.....	16
8	E-mail functionality via GPRS .....	16
8.1	Configuration of the e-mail functionality.....	17
8.2	Additional e-mail configuration possibilities.....	18
9	Access the STD35 from the internet .....	20
9.1	Prerequisites .....	20
9.2	Registration to the web-server of the STD35.....	20
9.3	"Status"-Page .....	21
9.4	"Photo"-Page.....	23
9.5	"Basic Configuration"-Page .....	24
9.6	"Advanced Configuration"-Page.....	26
9.7	"Clip List"-Page .....	32
9.8	"Logout"-Page .....	32
9.9	Detailed example .....	32
9.10	Configuration via SMS .....	33
9.11	Configuration via web interface.....	33
10	Connecting the camera .....	34
11	Configuration Tool.....	35
12	Troubleshooting .....	36
13	Wiring examples.....	37
14	Accessories.....	39
15	Technical data.....	40
16	Document history .....	40

## 1 Introduction

Thank you very much for purchasing our Telic STD35 telemetry device!

The STD35 offers the user the possibility to remotely switch ON or OFF electronic devices and to receive alarm messages via (SMS). You can switch devices either with an SMS or using a simple toll free voice call. Alarm messages (SMS) can be received with any mobile phone supporting SMS functionality.

With the new generation of the STD35 you now also have the possibility to receive alarm messages via e-mail. With the help of the digital camera (which is available as an accessory) pictures can be taken and sent via e-mail triggered by an alarm.

The STD35 has an integrated webserver which allows direct access to the device via the internet and a standard web browser (e.g. Internet Explorer or Firefox) from a computer or a mobile phone with web functionality. Thus it is very simple to switch electrical devices remotely and to change the configuration of the STD35 from anywhere. Configuration can also be done using the optional Telic STD35 configuration tool from any PC, professional users can use this tool to configure the device without using SMS.

The STD35 now also has an integrated battery backup which ensures smooth operation even during periods of brief power loss.

We wish you success and joy in using your new STD35!

### **Concerning the user manual:**

This document is meant to help you use the various functions of the device in the most optimal way possible. Therefore we ask you to please read this manual carefully and completely.

If you are in a hurry and want to make yourself familiar with the more detailed aspects of the product later then please read chapter 6 "Quick Start-up" first.

There you will find all the necessary information getting the device operational in a short period of time.

The information in this document has been gathered after thorough inspection but they are not to be taken as assurance of end product properties.

The written approval of Telic GmbH is mandatory before you can pass on or reproduce this documentation for this product or the software or use the content.

Telic reserves the right to change the data mentioned here without prior notice and does not take any responsibility for technical inaccuracies and/or omissions. This manual has been thoroughly checked; should you nevertheless find an error or want to express criticism or make suggestions, please send an e-mail to

**E-mail: [support@telic.de](mailto:support@telic.de)**

Oberhaching, 9th16.Jun. 2011

© 2011 Telic GmbH, Oberhaching, Germany

## 1.1 Attention, please read this

This user manual contains important information for start-up and use of the STD35. Read it carefully before you start working with the STD35.

The warranty will be null and void should damage occur due to non-compliance with these instructions for use. We cannot accept any responsibility for consequential loss.

We cannot be held responsible for material loss or personal injury that is due to incompetent use or non-compliance with the safety instructions. The warranty will be null and void in such circumstances.

The STD35 contains highly integrated components which can be damaged by electrostatic discharge.



Therefore only touch the STD35 on the edges and avoid touching the pins of components on the board.

During the operation of the STD35 it can happen that SMS messages are sent out automatically or that GPRS connections will be built up which will generate costs similar to those of your mobile phone. Your mobile network provider will invoice those costs to you.

### Safety Instructions



When using products which are exposed to electric voltage the valid VDE-regulations have to be observed. Especially VDE 0100, VDE 0550/0551, VDE 0700, VDE 0711 and VDE 0860 are applicable.

- All wiring work has to be done in a voltage free state only
- All cables and wires which are energized and connected to the device, the module, or components have to be checked regularly for any damage to the isolation shielding or fractures in the cables. If the supply cables are visibly damaged the device has to be taken out of operation immediately until the faulty cable has been exchanged
- Before putting a device into operation, it has to be clarified, whether this device or module is appropriate for the field of application. In case of doubt ask a specialists or the manufacturer of the device.
- Please note that we are not responsible for any errors in usage or connection. Therefore we cannot accept any responsibility for consequential loss.
- Before opening the device always disconnect the mains adapter or make sure that the device is disconnected from the power supply.
- Components, modules or devices have to be built into a housing before they are put into operation. During installation they should not be connected to any power supply.
- You should only use tools on components, modules, or devices if they are disconnected from the power supply, and residual electric charge (which may still be stored in some components inside the device) has been discharged.
- When using components or modules it is necessary to strictly observe the specification given in the corresponding description of these components.
- If a description for a private end-customer does not clearly state which electric data is valid for a component or a module, how to wire the device, which external components, or additional devices can be connected or which parameters these components are allowed to have, a specialist must be contacted.
- Devices which operate with greater than 35 Volts have to be connected by a specialist.
- Before putting the device into operation it should be checked that there is no current leakage on the housing.
- In case measurements with the opened housing are necessary, an isolating-transformer has to be used for safety reasons. Alternatively the voltage can be supplied by an appropriate power supply which complies with the safety regulations. All wiring work has to be done in a voltage free state only.

## **2 Background Information**

### **2.1 GSM-Network in general**

The GSM Network (Global System for Mobile Communications) is a standard for all-digital mobile phone networks. GSM has been created to provide a mobile telephone system offering the users Europe wide mobility and voice services compatible with ISDN or analog services.

Originally GSM has been designed for voice calls, the transmission of text messages (SMS) and the transmission of data with a constant data speed. With the success of the internet an evolution of GSM started. The GSM network was expanded to offer packet oriented data transmission (e.g. via GPRS) while keeping all other features and being fully downwards compatible.

### **2.2 GPRS**

GPRS (General Packet Radio Service) is a packet oriented transmission service which is used in the mobile networks and which is supported by almost all network providers.

With GPRS you only have a virtually existing permanent connection to the other party. Only when you really transmit data will the channel will be used, otherwise it is free for other users. This means that no channel will be reserved permanently for a user (as it is with a GSM voice call). Therefore the *GPRS*-bills depend more on the actual data volume transmitted than on the connect time.

If the device is booked into the GPRS-Net it will automatically be assigned an IP-Address and can exchange data with any server accessible via the internet,

Before you can use the GPRS-Interface the SIM-Card must be activated for GPRS. To order this functionality please talk to your mobile network provider.

### **2.3 Quad band Frequencies**

When a device is "quadband" it means that it uses the four major GSM frequencies and that it is compatible with most GSM networks worldwide.

These four frequencies are 850 MHz and 1900 MHz (on the American continent) and 900 MHz and 1800 MHz, which are used in almost all other countries worldwide (Europe and Asia).

In contrast to a triband mobile phone which only supports 900/1800 and 1900 or 850/1800 and 1900 a quadband device can be used in almost every GSM network worldwide.

### **2.4 Internet in general**

The internet is today a worldwide network consisting of many computer networks to enable the exchange of data. It offers the use of internet services such as www, e-mail, FTP or VoIP (voice call).

In theory every computer can be connected to any another computer in the world. The data exchange between the internet computers is handled with the standardized internet protocol (IP).

### **2.5 E-mail via SMTP**

SMTP (Simple Mail Transfer Protocol) is a method used to send e-mails over the internet. The handling will be done by a mail programme, which is running in this case on the STD35 and which supports SMTP. For the user this process is invisible. This programme establishes a connection to a SMTP server which will transport the e-mail to the given e-mail address with the help of further SMTP-servers if necessary.

To be able to use this service you must have an e-mail account with a mail provider (e.g. AOL or Yahoo) and the following settings have to be made which are different for every mail provider (e.g. AOL or Yahoo).

- Name of the SMTP Server (e.g. smtp.mailprovider.com or 192.168.234.12)
- User name to register to the SMTP Server
- Password to register to the SMTP Server

The device comes pre configured to use the free Telic email server. If the user wishes to use there own email service it is important to note it must support plain text authentication.

To see which settings have to be used on the STD35 to be able to take advantage of this service please read chapter 8.

## 2.6 Web Server

A webserver is a program which runs on a device (the server) that sends data and documents to clients (standard web browsers such as Internet Explorer or Firefox). Web-servers are mainly used as www-service in the internet. The data and documents can be retrieved and read from any computer connected to the internet worldwide.

Such a webserver has also been implemented on the STD35. To use this function several particularities have to be observed. You can find more detailed information in chapter 9.

## 2.7 Fixed IP

IP-Addresses are used in computer networks based on the internet protocol (IP) to transport data from the sender to the addressee. The internet is an example of such a computer network.

To be able to address a webserver the IP-address must be known in order to allow the web browser to download data from that webserver and show it to the user. Therefore servers usually always have an IP address which stays the same (fixed IP address).

The most common notation of the IP addresses used today consists of four figures, between 0 and 255, which are separated by a period, e.g. 127.0.0.1.

To be able to use the webserver on the STD35 the mobile network provider must assign a fixed IP address to the device and allow it a connection to the internet. This function is typically available on request only or with special GSM network providers.

## 3 Operating Conditions

Operate the STD35 only with a supply voltage between 5-32V DC and have in mind the polarity! (see picture1) Use a stabilized power supply with minimum 1A output current. (We recommend using only the original Telic power supply). If you use a mains adapter for power supply it has to conform to the VDE regulations.

- Loads connected to the device are not allowed to exceed 30 W per relay.
- The maximum output voltage is 30 V AC/DC
- The maximum switching power per relay is 1 A
- When installing the device make sure that the supply cable has a sufficient diameter
- During operation the temperature has to be between -30° and 75° Celsius.
- Protect the device from humidity, spray water and heat.
- In case of condensation allow a period of about 2 hours for acclimatisation.
- Do not operate the device in areas where inflammable gas, vapours, or dust are or could be present.
- Do not expose the device to heavy vibrations.
- The unit may only be repaired by a specialist.
- Only original parts have to be used when repairing the unit. The use of differing spare parts can cause serious material loss or personal injury.
- Keep the device away from flower vases, bath tubs, washbasins, liquids etc.
- No special operation position of the device has to be observed.

## 4 Proper Use

The device is designed for the remote switching of devices via the GSM network as well as the remote retrieval of status information of the inputs and the generation of SMS messages or e-mails after status has changed at the inputs. A different utilisation of the device other than the one described above is not allowed.

## 5 Introduction

The STD35 is a telemetry module which is easy to install and simple to use. It can be configured using any GSM mobile phone, SMS capable software, or the Telic STD35 configuration tool (sold separately).

With the STD35 you can control five relays and monitor the status of two digital inputs with one or several common mobile phones.

Apart from the STD35 you only need a valid SIM Card of any network provider (GSM850 / 900 / 1800 or 1900 MHz)

While using prepaid SIM-cards one shall always keep aware of the amount of remaining credit left on the card, so that in case of alarms a message can be sent.

Typical fields of application are

- the opening of (garage) doors
- switching on and off light and alarm devices as well as generating alarm messages (SMS or e-mail)
- the retrieval of information from door sensors, movement sensors or level sensors
- etc.

You can for example open your garage door with a call or get a message (via SMS or e-mail) in case your house alarm system gets triggered. In connection with the Telic camera you can get a photo via e-mail when a movement sensor connected to the STD35 detects movement.

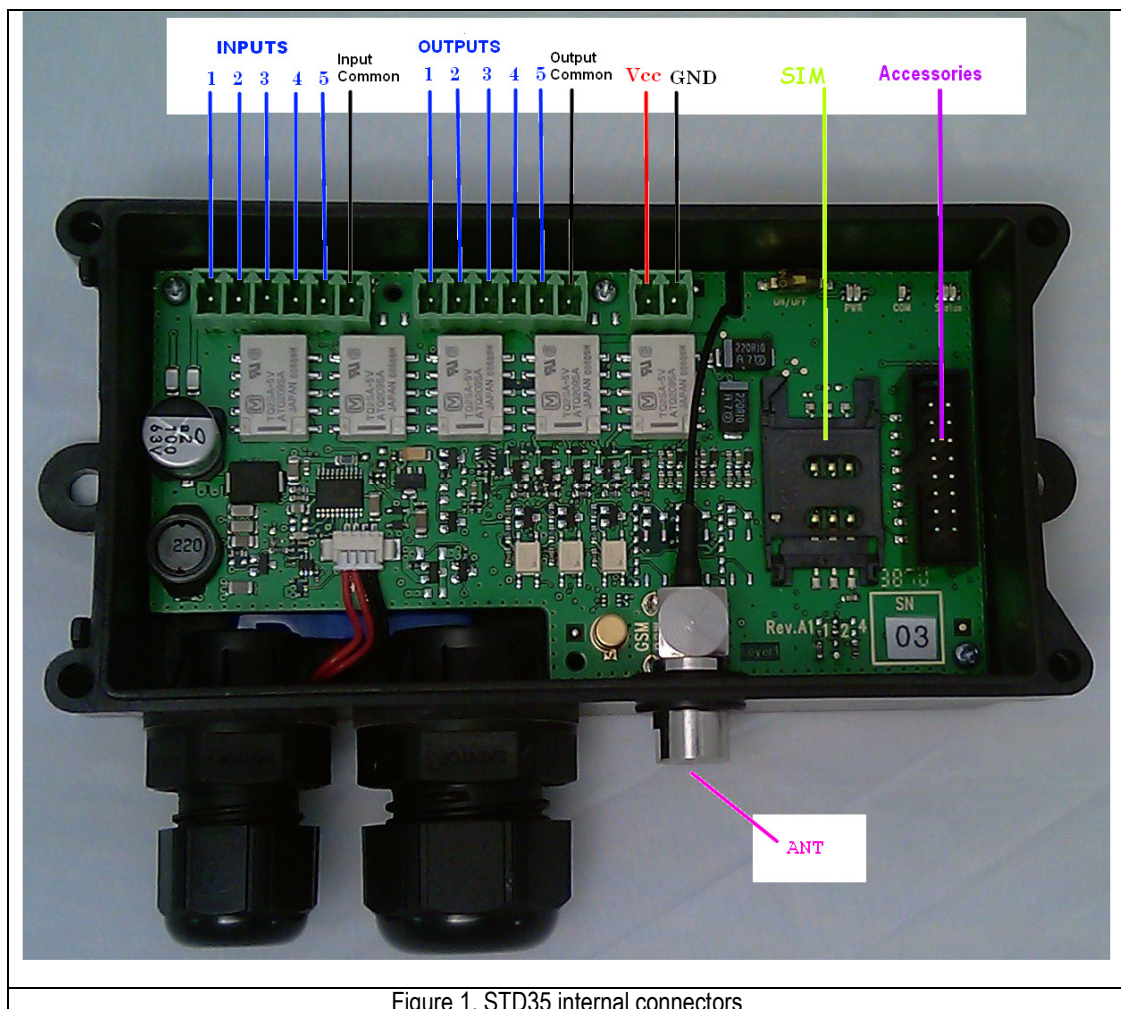

Figure 1. STD35 internal connectors

**Connectors:**

As described in figure 1 the STD 35 has 3 Green Screw terminals. One connector is for the 5 inputs (3 digital and 2 analog/digital). Another connector is for the 5 outputs which are all driven by relays. And the third screw terminal connector is for the power supply.

There is also a small power switch between the power connector and the LEDs. This switch is used to turn the device on and off.

On the right side of the diagram an additional accessory interface connector is shown. This connector is for use with the optional CMOS camera or the Telic Configuration tool.

ANT: connect the GSM antenna with FME-female connector here.

Please observe the maximum output voltage of the relays and the maximum input voltage of the inputs! In chapter 3. "Operating conditions" you will find further information on this.

**LED Signals:**

The STD35 has several LEDs which can be used to determine the current state of the device.

There are two power LEDs. A red power led that is illuminated when charging is taking place, when not charging (battery full, or no charger is connected) it is off. A green power led saying that is illuminated whenever the device is on. Normally this led reflects the state of the power switch.

There is also a green "COM" led it gives information regarding the current GSM status:

- stable in indicates the device is not currently booked into the GSM network
- blinking once every 2 seconds indicates the device is booked into the GSM network as normal.

There are also separate red and green status LEDs. Under normal operating conditions these two LEDs are not illuminated. However status red and status green can toggle if there is no configuration yet (when in factory default state). The status LEDs and GSM led (COM) will blink twice if no simcard (or an invalid simcard) has been inserted. The status LEDs and GSM led (COM) will blink three times if the SIM PIN is different than "0000" or "2468".

**Switch:**

There is also a small power switch between the power connector and the LEDs. This switch is used to turn the device on and off.

## 6 Quick start-up

In the following section it is described step by step what you have to do to begin using the STD35 without extensive setup.

### 6.1 General preparations

You need an activated SIM card of a GSM network provider. The PIN of this card has to be set to "0000" (4 times zero).

Alternatively you could use the PIN "2468". To change the PIN you can use a common mobile phone. The instructions how to change the PIN are described in the manual of your mobile phone.

**If you use a SIM card with a PIN different from "0000" or "2468" in the STD35, the STD35 will use a "wrong" PIN. After the second attempt to power up the device your SIM card will be blocked. In this case you need to use the "Super-PIN" or "PUK" to assign a new PIN to your card. Please look into the user guide of your mobile phone. There you find how to use the PUK to de-block the SIM card.**

Should you wish to use a SIM card which does not require a PIN, this is also possible and the STD35 recognizes this and will behave accordingly.

In the following we will refer to the "master mobile" as the mobile telephone which you want to use to switch the outputs **and** to configure the STD35 via calls.

To be able to administer the STD35 with your master mobile it is necessary that the "incognito" or "private call" function of the mobile is deactivated. This means the master mobile **has to** transmit the mobile telephone number with every call. To change the settings please refer to the user guide of your mobile telephone. To test the setting you can call a different mobile phone; there your phone number or name should be displayed.

### 6.2 Hardware preparations

Before connecting the supply voltage and switching on the STD35 please insert the SIM card into the SIM card holder on the backside of the STD35: To open the SIM card holder move it sideways and flip it open; insert the card (mind the proper orientation of the card) and close it again. To lock it in place move the top sideways in the opposite direction.

Now please connect the GSM antenna which is included to the antenna connector on the STD35 board.

After that connect the power supply to the power supply connector.

**Please always observe the polarity (see Figure 1) and that you have a proper power supply. (see chapter 3."Operating Conditions")**

### 6.3 Configuration Call

After having connected the power supply and turning the device on the green power LED will be illuminate (system start). Shortly after that the GSM LED will be activated. Now the STD35 will automatically try to connect to the GSM network. As soon as this is done, the GSM LED will be flashing once every 2 seconds. As soon as the red and green system LED are toggling the STD35 is ready and waiting for the configuration.

Now call with master mobile the phone number of the SIM card which is inside the STD35. The STD35 will accept the call and cancel it a few seconds later. During this call, a four digit DTMF sequence is sent to the caller and you will hear them on your mobile phone. With this call the STD35 is configured to the master mobile.

**NOTE: when calling with the master phone it is necessary caller ID is not blocked, or configuration call will not work correctly!**

Pay attention:

As long as the STD35 still has the factory defaults it shows this by the toggling the red and green system LEDs. From this moment on you have three minutes to configure the STD35 with the configuration call.

After 3 minutes (without configuration call done in between) the device switches off. If you switch it on again afterwards the STD35 is again expecting the configuration.

In case the STD35 will be disconnected from the power supply after a successful configuration by a power failure it will automatically send a SMS/E-mail with the text "START-UP ALARM" to the preconfigured telephone number as soon as the power supply is established again.

#### **6.4 Quick configuration check**

To check whether the configuration was successful you can now make the following quick configuration check.

Take your master mobile and call the telephone number of the SIM-Card inside the STD35. This call should be cancelled by the STD35 and the Relay 1 should switch for one second.

Now the basic configuration is done which means that all future events will be sent to the master mobile and that Relay 1 can be switched from that mobile phone.

To use the additional functions of the STD35 please continue reading chapter 7 "SMS commands"

### **7 SMS Commands**

In order to configure the device, request information from it, or trigger certain actions special commands are used. All the commands are designed to be easy to enter even when using a standard phone to send them via SMS. This chapter of the manual describes all the commands the device will understand and how to use them.

With the optional Telic configuration tool available for the STD35, you can make all the settings below from the comfort of your PC. Using the Configuration tool you can also download them to the STD35 using the serial cable.

## 7.1 Table of SMS command

<b>Configuration Commands</b>	
R:	reset default device settings
ST?	request device status SMS
S:	1 - enable startup SMS 0 - disable startup SMS
C2:	set phone number nr 2
C3:	set phone number nr 3
C4:	set phone number nr 4
C5:	set phone number nr 5
PN:	set different password (max 4)
E1:	set message text for INPUT 1 event (max 64)
E2:	set message text for INPUT 2 event (max 64)
E3:	set message text for INPUT 3 event (max 64)
E4:	set message text for INPUT 4 event (max 64)
E5:	set message text for INPUT 5 event (max 64)
PT:	set message text for POWER-UP event (max 64)
<b>Inputs &amp; Outputs commands</b>	
O1ON	turn relay 1 on
O1OFF	turn relay 1 off
O2ON	turn relay 2 on
O2OFF	turn relay 2 off
O3ON	turn relay 3 on
O3OFF	turn relay 3 off
O4ON	turn relay 4 on
O4OFF	turn relay 4 off
O5ON	turn relay 5 on
O5OFF	turn relay 5 off
O1:xxxxx	defines time period for relay 1 action (in seconds)
O2:xxxxx	defines time period for relay 2 action (in seconds)
O3:xxxxx	defines time period for relay 3 action (in seconds)
O4:xxxxx	defines time period for relay 4 action (in seconds)
O5:xxxxx	defines time period for relay 5 action (in seconds)
A1:xxxxx	defines delay for relay 1 action (in seconds)
A2:xxxxx	defines delay for relay 2 action (in seconds)
A3:xxxxx	defines delay for relay 3 action (in seconds)
A4:xxxxx	defines delay for relay 4 action (in seconds)
A5:xxxxx	defines delay for relay 5 action (in seconds)
I1:xxx	debounce time for input 1 (in seconds)
I2:xxx	debounce time for input 2 (in seconds)
I3:xxx	debounce time for input 3 (in seconds)
I4:xxx	debounce time for input 4 (in seconds)
I5:xxx	debounce time for input 5 (in seconds)
V1:x	1 - invert input 1 0 - normal input 1
V2:x	1 - invert input 2 0 - normal input 2
V3:x	1 - invert input 3 0 - normal input 3

V4:x	1 - invert input 4 0 - normal input 4
V5:x	1 - invert input 5 0 - normal input 5
A1L:	set analog input 4 low threshold (millivolts)
A1H:	set analog input 4 high threshold (millivolts)
A2L:	set analog input 5 low threshold (millivolts)
A2H:	set analog input 5 high threshold (millivolts)
BAT:	set low battery threshold (millivolts)
<b>CLIP commands</b>	
CL:	add clip list number, asterisk symbol (*) is also supported
CD:	remove clip list number
<b>DATA commands</b>	
EMAIL:	1 - enable email feature 0 - disable email feature default is enabled
SMTPIP:XXXXX	defines SMTP server IPv4 address example SMTPIP:"smtp.aol.com" max length is 32
SMTPPORT:	defines SMTP server PORT example SMTPPORT:2121 value must be a number, in range 0.. default is 25
APN:	defines GPRS APN (for emails and web) example APN:internet max length is 32 default is internet
APNUSR:	defines GPRS USERNAME (for emails and web) example APNUSR:Patryk max length is 32 default is empty
APNPWD:	defines GPRS PASSWORD (for email and web) example APNPWD:Patryk max length is 32 default is empty
SMTPLUSR:	defines smtp username (used for authentication - this is not APN username!) example SMTPLUSR:"p.szymczak" max length is 64 (according to RFC0821, chapter 4.5.3. SIZES) default is empty
SMTPPWD:	defines smtp password (used for authentication - this is not APN password!) example SMTPPWD:"p.szymczak" max length is 64 (according to RFC0821, chapter 4.5.3. SIZES) default is empty
FROM:	defines email sender example FROM:"p.szymczak@cetec.cc" max length is 25 default is empty
TO:	defines up to 5 email recipients (separated by ";"), each one max 25 characters

	example TO:"p.szymczak@telic.pl" max length of field is 129 [(5*25+1)-1] default is empty
TO1:	defines additional recipient address for INPUT 1 event
SUB1:	defines email subject that will be sent to "TO1" address
TO2:	defines additional recipient address for INPUT 2 event
SUB2:	defines email subject that will be sent to "TO2" address
TO3:	defines additional recipient address for INPUT 3 event
SUB3:	defines email subject that will be sent to "TO3" address
TO4:	defines additional recipient address for INPUT 4 event
SUB4:	defines email subject that will be sent to "TO4" address
TO5:	defines additional recipient address for INPUT 5 event
SUB5:	defines email subject that will be sent to "TO5" address
TO6:	defines additional recipient address for STARTUP event
SUB6:	defines email subject that will be sent to "TO6" address
TO7:	defines additional recipient address for CALL event
SUB7:	defines email subject that will be sent to "TO7" address
TO8:	defines additional recipient address for PHOTO event
SUB8:	defines email subject that will be sent to "TO8" address
TO9:	defines additional recipient address for MOTION event
SUB9:	defines email subject that will be sent to "TO9" address
TO10:	defines additional recipient address for STATIONARY event
SUB10:	defines email subject that will be sent to "TO10" address
BODY:	defines general body content that can contain substitution variables
<b>WEB commands</b>	
WEB:	1 - enable web feature 0 - disable web feature default is enabled
WUSER:	set username for web (max is 32) default value is STD35
WPASS	set password for web (max is 32) default value are last 4 digits of IMEI number
<b>Camera commands</b>	
CAM:	0 - disable camera feature 1 - enable camera feature with photo size 80×64 3 - enable camera feature with photo size 160×128 5 - enable camera feature with photo size 320×240 7 - enable camera feature with photo size 640×480 default is 7 - enabled, with the biggest photo size
PHOTO	used without any parameters, triggers email with cam photo sending
MOTION:	set motion sensitivity parameter (default is 3), max is 9
STATIONARY:	set stationary parameter (default is 60), max is 999
MTEXT:	set message text for MOTION event (max 64)
STEXT:	set message text for STATIONARY event (max 64)
MS:	1 - enable motion sensor feature 0 - disable motion sensor feature default is enabled
FS:	1 - enable first stationary event 0 - omit first stationary event
<b>DOTA commands</b>	

DOTAAPN:internet.DOTAAPNUSR:"".DOTAAPNPWD:"".DOTAREQ.	
DOTAUSR:	set FTP username (max 16)
DOTAPWD:	set FTP password (max 16)
DOTASERVER:	set FTP server IPv4 or domain (max 64)
DOTAFILE:	set filename (max 64)
DOTAAPN:	set APN (max 24)
DOTAAPNUSR:	set APN username (max 12)
DOTAAPNPWD:	set APN password (max 12)
DOTAREQ	trigger DOTA
<b>Misc commands</b>	
VERSION?:	requests current software version

## 7.2 Variable substitution

In order to display some information in event texts it is possible to include in event text strings “variables”. When a variable is included in an event text string, the variable is replaced by the value it is intended to represent in the string that is sent to the user, either via SMS or email.

The following table describes the available variables and the data they represent

### Substitution variables

\$CALID\$	last incoming CLIP number
\$CNT\$	X/Y (where X is sent SMS counter and Y is sent EMAIL counter)
\$IN1\$, \$IN2\$, \$IN3\$, \$IN4\$, \$IN5\$ \$OUT1\$, \$OUT2\$, \$OUT3\$, \$OUT4\$, \$OUT5\$	current input value as a string (LOW or HIGH)
\$IN1T\$, \$IN2T\$, \$IN3T\$, \$IN4T\$, \$IN5T\$ \$OUT1T\$, \$OUT2T\$, \$OUT3T\$, \$OUT4T\$, \$OUT5T\$	current relay value as a string (ON or OFF)
\$VIN4M\$	current input value as a integer (0 or 1)
\$VBATM\$	current relay value as a string (0 or 1)
\$VBAT\$	battery voltage in millivolts (integer)
\$VMAINSM\$	battery voltage in volts (float)
\$VMAINS\$	mains voltage in millivolts (integer)
\$VIN4M\$	mains voltage in volts (float)
\$VIN4\$	input 4 voltage in millivolts (integer)
\$VIN5M\$	input 4 voltage in volts (float)
\$VIN5\$	input 5 voltage in millivolts (integer)
	input 5 voltage in volts (float)

Example: E1:battery=\$VBAT\$. This will send a text message that returns to the configured number the current battery voltage in the message.

### Send SMS Commands

By sending a SMS to the STD35 you can switch the outputs or make individual configuration settings.

Those SMS have the following format which is described below:

In order to avoid unauthorized usage, every configuration command to the STD35 must start with a 4-digit password. Control commands (for example: switching an output or status requests) do not require a password.

The last four digits of the IMEI being the password for your device must always be kept a secret. In this example the keyword is “4244”.

**The IMEI cannot be changed!** Although the password can be changed if needed for security purposes, you should keep in mind that every command – including setting back to factory settings – requires the knowledge of the password.

All commands (except R: and ST?) must end with a full stop “.”!

All commands can be sent in one SMS; each command has to be separated from the next by a full stop (see examples).

The parameters for the seconds e.g. command “O1:xxxx.” can have 1-5 digits. Valid parameters are e.g. 1 (for 1 second), 90 (for 90 seconds) or 99999 for (99999 seconds). No leading “zeros” have to be added. Example: “O1:110” stands for 110 seconds.

**Please observe the difference between the figure ‘0’ and the letter ‘O’!. (“O1ON.” contains twice the letter O; “V1:0.” contains once the figure 0)**

A configuration command should look like the following example:

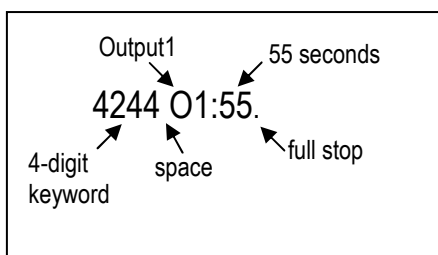

### 7.3 Explanation of the commands

Switching outputs via SMS

- After the STD35 has received a SMS with the text “O1ON.” (Output 1 ON) from the configured mobile phone, the relay 1 switches for one second. With the SMS “O2ON.” relay 2 switches for one second.
- To get feedback of the actual status of the inputs and outputs just send a SMS with “ST?”

Configuration-SMS (attention 4-digit keyword required!)

- The SMS “R:” is sets the STD35 back to the factory settings. Please note that this SMS can be sent from **any** mobile phone as long as the 4-digit keyword is known. This ensures that the STD35 can still be used even if the original master mobile (phone number) is no longer available.
- You can activate or deactivate the Start-up SMS (START-UP ALARM) with the SMS “S:x.” (x = 1 or 0).
- To activate the web-server send a SMS with the command “WEB:1:”, to deactivate the webserver “WEB:0:”
- A SMS with the text “O1:xxxx.” or “O2:xxxx.” (xxxxx = seconds) configures the switching time of the relays. The STD35 saves these settings so that they are still available after the supply voltage has been restored.
- If the switching time has been set to 0 by a configuration SMS the corresponding relay switches permanently at every call. If the relay has been active before it will afterwards be inactive and vice versa. In this case a SMS with the text “O1ON.” from the configured mobile phone switches the relay 1 permanently on. A SMS with “O1OFF.” permanently switches off relay 1. Relay 2 reacts accordingly to SMS messages with “O2ON.” and “O2OFF.”.
- The SMS “A1:xxx.” or “A2:xxx.” (x = seconds) sets the delay after which a reply SMS is sent after an output has been activated. This can be helpful if you want to switch something on or off and would like to measure the result of this output control with one of the inputs of the STD35. Therefore the new status *after* the switching of the output is transmitted.
- With a SMS containing the text “I1:xxx.” or “I2:xxx.” (xxx = seconds) you can configure the time the inputs have to be activated before the STD35 sends out an alarm SMS
- A SMS with the text “V1:x.” or “V2:x.” (x = 1 or 0) can change the polarity of the inputs. If x=1 an alarm SMS will be sent in case the input has not been activated for the configured time. The default value is x=0 which means that the STD35 will send an event alarm in case the input has been **activated** longer than the configured time.

Please note that the brackets “<” and “>” in the following commands are not part of the commands but are included in order to increase the readability of the overview!

Four additional alarm numbers (mobile phones) can be defined using C2: - C5: commands. These numbers are allowed to set relay 1 by a call and they are informed via SMS in case of Start-up or events. These numbers are not allowed to send configuration SMS messages unless they include the password in the SMS.

**If an alarm number is given in international format, the number must start with '+'. (e.g. +491721234567)**

- With the "PN:<4digit password>." command the password can be changed. The password can include letters and figures but no special characters are allowed. All letters have to be in capital. The standard password (factory setting) is the last 4 digits of the IMEI (see chapter SMS Commands).
- The texts of the event or start-up SMS can be changed with the commands "E1:<text1>.", "E2:<text2>." and "PT:<startup text>.". The message length must not exceed 64 characters. **Do not use command syntax inside a message text. The '.' is the terminating character of the text. Each new text must be sent in a separate SMS.**
- You can generate an extended clip list of 500 clip numbers. The numbers stored in the clip list are allowed to switch relay 1 with a phone call. Use "CL:" to generate the clip list and add further phone numbers. With "CD:" you can delete a phone number from the list. Be aware that you cannot read out the clip list (getting SMS messages) because it could by far exceed the size limitation of SMS texts.

Please note that all commands listed in the section "Configuration SMS" require the 4-digit keyword at the beginning.

#### 7.4 Examples for SMS Commands

**Please note that for these examples the 4-digit password 4244 has been chosen. Instead of this password you have to use your 4-digit password of your STD35!**

Start-up alarm off, relay 1 on, relay 2 off, time of activation of input 1: 5 sec.:      **4244 S:0.O10N.O2OFF.I1:5.**

Switching time of relay 1 = 90 seconds:      **4244 O1:90.**

Reset settings to factory settings:      **4244 R:**

Configuration of the second alarm number:      **4244 C2:+491721234567.**

Deleting a alarm number:      **4244 C2:.**

Configuration of a new password:      **4244 PN:AB12.**

Adding a new clip to the extended clip list:      **4244 CL:+491721234567.**

Removing the clip from the extended clip list:      **4244 CD:+491721234567.**

Configuring the device for updating over the air:

**4244DOTAUSR:picotrack. DOTAPWD:picotrack. DOTASERVER:"www.cetec.cc". DOTAFILE:"std35quad-1.2.20.tki".**

**4244 DOTAAPN:web.vodafone.de**

**.DOTAAPNUSR:vodafone.DOTAAPNPWD:vodafone.DOTAREQ.**

## 8 E-mail functionality via GPRS

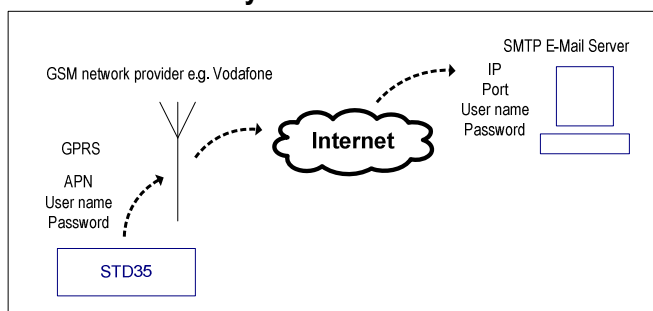

The STD35 offers you the possibility to get messages via SMS and via e-mail.

## 8.1 Configuration of the e-mail functionality

By default if the user has correctly configured the APN settings and the receiver email address email functionality should work. This is because smtp settings are by default already configured using the Telic email server.

If no camera is connected to the device it is recommended to issue the command CAM:0 to the device in order to avoid delays due to unnecessary camera synchronization time.

By default if the user has correctly configured the APN settings and the receiver email address email functionality should work. This is because smtp settings are by default already configured using the Telic email server.

If you need a full stop "." in a parameter as it is for example in an e-mail address, the complete parameter has to be put into inverted commas ("...") (e.g. "h.muster@aol.com"), as otherwise the "." would be seen as the end of the command.

Additionally you have to take care to send the 4-digit keyword at the beginning of each configuration SMS.

To be able to use the e-mail functionality the following parameters have to be set.

GPRS settings (to set up an internet connection)	
Name of the APN (Access Point Name)	APN:<text>.
User name for APN	APNUSR:<text>.
Password for APN	APNPWD:<text>.

- With the commands "APN:<text>.", "APNUSR:<text>." and "APNPWD:<text>." you make the basic settings to build up a GPRS (internet) connection. You need to get the necessary data from your GSM network provider

**Example (Vodafone, Germany):**

The GSM network provider Vodafone gives you the following details:

APN: web.vodafone.de  
User: vodafone  
Password: vodafone

Thus you would have to send the following SMS:

4244	APN:"web.vodafone.de".	APNUSR:vodafone.	APNPWD:vodafone.
	↑ APN	↑ User-name	↑ Password

SMTP settings (to send e-mails)	
IP- Address of the SMTP Server	SMTPIP:<text>.
Port of the SMTP Server	SMTPPORT:xxxxx.
User name for SMTP Server	SMTPLUSR:<text>.
User password for SMTP Server	SMTPPWD:<text>.

- The commands "SMTPIP:<text>.", "SMTPPORT:xxxxx.", "SMTPLUSR:<text>." and "SMTPPWD:<text>." are necessary to make the settings on the SMTP server side. Please contact your SMTP provider regarding the required data.

**Example (AOL, Germany):**

The SMTP server provider AOL has given you the following details:

Server name: smtp.de.aol.com  
Server port:25  
User name: Hans.Muster  
Password: Muster

Thus you would have to send the following SMS:

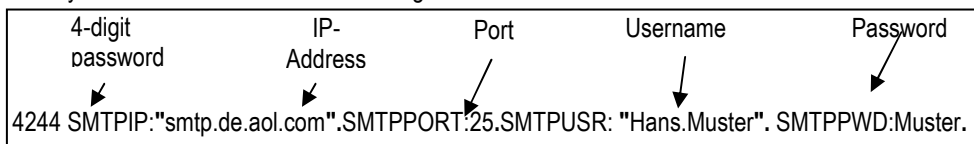

**Specific settings:**

Recipient for e-mail transmission	
Recipient e-mail address	TO:<text>.

- With the command "TO:<text>." you define the recipient e-mail address. You can list up to 5 e-mail addresses each separated by a < ; >. The max. length per e-mail address is 25 characters. Default status: no e-mail address is entered. If at least one e-mail address is defined an e-mail transmission is started at following events: start up, input1, input 2.

**Example:**

You want to send an e-mail after an Event to the address peter\_muster@aol.com.

Thus you would have to send the following SMS:



If you do not want to send further event e-mails please delete all e-mail recipients by sending an "empty" TO command

e.g. 4244 TO: "" . to delete all e-mail addresses

**8.2 Additional e-mail configuration possibilities**

You can make further configuration settings for the e-mail functionality. With the following commands you can define e-mail recipients who should only get an e-mail in case of a certain event.

TO1:	defines additional recipient address for INPUT 1 event
SUB1:	defines email subject that will be sent to "TO1" address
TO2:	defines additional recipient address for INPUT 2 event
SUB2:	defines email subject that will be sent to "TO2" address
TO3:	defines additional recipient address for INPUT 3 event
SUB3:	defines email subject that will be sent to "TO3" address
TO4:	defines additional recipient address for INPUT 4 event
SUB4:	defines email subject that will be sent to "TO4" address
TO5:	defines additional recipient address for INPUT 5 event
SUB5:	defines email subject that will be sent to "TO5" address
TO6:	defines additional recipient address for STARTUP event

SUB6:	defines email subject that will be sent to "TO6" address
TO7:	defines additional recipient address for CALL event
SUB7:	defines email subject that will be sent to "TO7" address
TO8:	defines additional recipient address for PHOTO event
SUB8:	defines email subject that will be sent to "TO8" address
TO9:	defines additional recipient address for MOTION event
SUB9:	defines email subject that will be sent to "TO9" address
TO10:	defines additional recipient address for STATIONARY event
SUB10:	defines email subject that will be sent to "TO10" address
BODY:	defines general body content that can contain substitution variables

- With the command "TOx:<text>." (**x = 1 to 10 see above**) you define the recipient e-mail address (**only for this event**). You can list up to 5 e-mail addresses each separated by a <;>. The max. length per e-mail address is 25 characters. Default status: no e-mail address is entered.
- With the command "SUBx:<text>." (**x = 1 to 10 see above**) the subject line of the e-mail is defined. The max. length is 128 characters per text. The default value is "STD35 x event"
- You can define the body text of all the e-mail events with the command "BODY:<text>." The max. length is 160 characters per body text. The default value is empty, meaning no text is sent.

#### Additional settings

Senders e-mail address	FROM:<text>.
Priority of the e-mail	PRIO:<x>.
E-mail as HTML or Text	HTML:<x>.
E-mail code	CHARSET:text>.
Sender in subject line	FROMSUB:text>.
Send attachment	ATT:<x>.
E-mail address in CC	CC:<text>.
E-mail address in BCC	BC:<text>.
Request picture via SMS	PHOTO.
Activate camera (on/off)	CAM:<x>.

- With the command "FROM:<text>." you can configure the sender e-mail address. The max. length is 25 characters. The default value is [noreply@telic.de](mailto:noreply@telic.de)
- "PRIO:<x>." sets the priority with which the e-mail will be displayed. Possible values are from 1 to 5. The default value is 3 (normal priority).
- With the command "HTML:<x>." you can define whether the e-mail should be sent as a HTML message or as a text message (1 = HTML and 0 = text). The default value is 0.
- With the command "CHARSET:text>." you indicate with which coding the e-mail will be sent. The default value is "UTF-8". Normally you do not have to change this.
- If you want to enter the sender into the subject line you have to send the command "FROMSUB:text>.". The max. length is 25 characters. No senders e-mail address is entered here as default value.
- With the command "ATT:<x>." you can configure whether an attachment should be send or not (1 = send attachment, 0 = no attachment). The default value is 1 (send attachment).
- If you want to put a recipient on CC (Carbon Copy) you can do this with the command "CC:<text>.". The max. length is 25 characters. No e-mail addresses are entered as a default value.
- To put a recipient in BCC (Blind Carbon Copy) use the command "BC:<text>.". The max. length is 75 characters.. No BCC e-mail addresses are entered as a default value
- To make a picture and send it via e-mail send the SMS command "PHOTO."

You can deactivate the camera functionality when the camera is connected to the STD35 with the command "CAM:0." and activate it with "CAM:x.". The camera offers different resolutions and you can select the desired camera resolution (x):

1 = 80 x 60

3 = 160 x 120

5 = 320 x 240

7 = 640 x 480

The default value is 7.

## 9 Access the STD35 from the internet

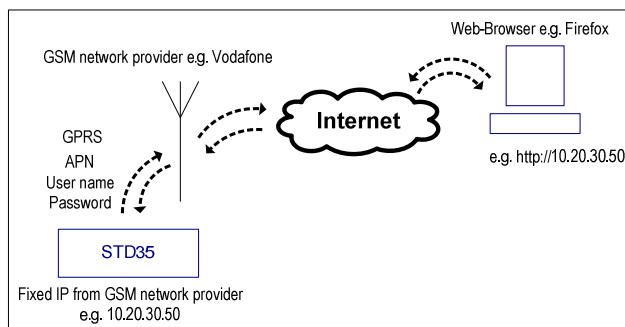

The web-server implemented in the STD35 allows you to set the outputs of the device and to make configurations from anywhere in the world with the help of a web interface and the internet.

### 9.1 Prerequisites

To be able to use this functionality you need a special type of SIM-Card:

You need a fixed IP address and the GSM network provider has to allow access to that IP and from the internet.

Furthermore you have to make the GPRS settings from chapter 8.1 to allow that the STD35 to establish a connection to the internet.

Please ask your GSM network provider for help.

After that you have to activate the web-server on the STD35 with a SMS command. Therefore please send the following SMS command to the STD35: "WEB:1."(see. chapter 7)

### 9.2 Registration to the web-server of the STD35

If your SIM card fulfils all the above requirements and if your GPRS settings have been correct you can access the IP address of your SIM card and register with the help of a standard web-browser (e.g. Internet Explorer or Firefox) to your STD35.

Your IP address might look like this example:

87.139.101.192 (Example)

Enter your IP address in the address line of your web-browser in the following format:

http://87.139.101.192 (Example)

After entering your IP address in your web-browser you will be asked to enter your user name and password.



Enter "STD35" as user name and as password the last four digits of the IMEI number (see chapter 7). Should you have changed the password you have to enter your password.

Now you will see the "Status"-Page of the STD35 web-server. This user interface is always in English. All available functions are described in detail in the following. Each chapter handles one of the Pages displayed on the web-surface:

- Status
- Photo
- Basic Configuration
- Advanced Configuration
- Clip List
- Logout

### 9.3 "Status"-Page



[Status](#) | [Photo](#) | [Basic Configuration](#) | [Advanced Configuration](#) | [Clip List](#)  
[Documentation DE](#) | [Documentation EN](#)

Device I/O status	
Input 1:	HIGH
Input 2:	LOW
Input 3:	LOW
Input 4:	HIGH
Input 5:	LOW
Output 1:	OFF
Output 2:	OFF
Output 3:	OFF
Output 4:	OFF
Output 5:	OFF

Relay Control		
Output 1	<input type="text" value="1"/>	OFF ▼
Output 2	<input type="text" value="1"/>	OFF ▼
Output 3	<input type="text" value="1"/>	OFF ▼
Output 4	<input type="text" value="1"/>	OFF ▼
Output 5	<input type="text" value="1"/>	OFF ▼

Counters	
SMS sent:	48
E-mails sent:	13

Under "Device I/O status" you can control the status of the inputs and outputs of your STD35. Under "Relay control" you can switch the outputs. Therefore you have to click on the drop-down menu of the respective output and select the desired state (ON = activate the output for the preconfigured time; OFF = switch of the output). To apply your settings to the STD35 press the "Accept" button.

## 9.4 "Photo"-Page

To retrieve a new picture from the connected Telic Camera which is available as accessory (see chapter 13) you have to select the "Photo"-Page and press the "Load"-button. How to connect the camera is described in chapter 10.

**Please note that the transmission of the picture may take some time depending on the quality of the GPRS network.**



[Status](#) | [Photo](#) | [Basic Configuration](#) | [Advanced Configuration](#) | [Clip List](#) | [Logout](#)

Attention! Loading of the photo may consume some time, depending on network conditions.  
Please, be patient!



In case the light intensity is not enough the infrared light of the camera will be activated automatically.

## 9.5 “Basic Configuration”-Page

To make all basic settings (see chapter 0) click on the “Basic Configuration”-Page.



[Status](#) | [Photo](#) | [Basic Configuration](#) | [Advanced Configuration](#) | [Clip List](#)  
[Documentation DE](#) | [Documentation EN](#)

IOs configuration									
Output 1 time	<input type="text" value="1"/>	Output 2 time	<input type="text" value="1"/>	Output 3 time	<input type="text" value="1"/>	Output 4 time	<input type="text" value="1"/>	Output 5 time	<input type="text" value="1"/>
Input 1 delay	<input type="text" value="6"/>	Input 2 delay	<input type="text" value="3"/>	Input 3 delay	<input type="text" value="6"/>	Input 4 delay	<input type="text" value="9"/>	Input 5 delay	<input type="text" value="12"/>
Input 1 debounce	<input type="text" value="1"/>	Input 2 debounce	<input type="text" value="1"/>	Input 3 debounce	<input type="text" value="1"/>	Input 4 debounce	<input type="text" value="1"/>	Input 5 debounce	<input type="text" value="1"/>
Invert input 1	<input type="text" value="inverted"/>	Invert input 2	<input type="text" value="inverted"/>	Invert input 3	<input type="text" value="inverted"/>	Invert input 4	<input type="text" value="inverted"/>	Invert input 5	<input type="text" value="inverted"/>

Message configuration	
Send start-up SMS	<input type="text" value="ON"/>
Password	<input type="text" value="1239"/>
Message 1 text	<input type="text" value="EVENT ALARM 1"/>
Message 2 text	<input type="text" value="EVENT ALARM 2"/>
Power-up message text	<input type="text" value="Hello world i am back"/>

CLIP configuration	
Master mobile (M1)	<input type="text" value="+4916099145695"/>
Clip 2 mobile (C2)	<input type="text"/>
Clip 3 mobile (C3)	<input type="text"/>
Clip 4 mobile (C4)	<input type="text"/>
Clip 5 mobile (C5)	<input type="text"/>

Web authorization	
Web access user name	<input type="text" value="STD35"/>
Web access password	<input type="text" value="1239"/>

**Under “I/Os configuration“ you can configure the inputs and outputs of your STD35.**

- “Output 1 time” and “Output 5 time”:  
This is the same as if you would send the SMS command “O1:xxxx.” or “O2:xxxx.” Etc.  
Here you set the switching time (**in seconds**) of the relays.  
If the switching time has been set to 0 by a configuration SMS the corresponding relay switches permanently at every call. If the relay has been active before it will afterwards be inactive and vice versa.  
In this case a SMS with the text “O1ON.” from the configured mobile phone switches the relay 1 permanently on. A SMS with “O1OFF.” permanently switches off relay 1. Relay 2 reacts accordingly to SMS messages with “O2ON.” and “O2OFF.”.
- “Input delay 1” and “Input delay 5”:  
This is the same as if you would send the SMS command “A1:xxx.” or “A2:xxx.” etc.  
This command sets the delay after which a reply SMS is sent after an output has been activated. This can be helpful if you want to switch something on or off and would like to measure the result of this output control with one of the inputs of the STD35. Therefore the new status *after* the switching of the output is transmitted.
- “Input debounce 1” and “Input debounce 5”:  
This is the same as if you would send the SMS command “I1:xxx.” or “I5:xxx.”  
Here you define for the inputs the time (**in seconds**) they have to be activated before the STD35 sends an alarm message (debounce).
- “Invert Input 1” and “Invert Input 5”:  
This is the same as if you would send the SMS command “V1:x.” or “V5:x.”  
Here you can invert the reaction of the inputs of the STD35. If “inverted” is selected the STD35 will send an alarm if the input **has not been activated** for the preconfigured time. The default value is “not inverted” which means the STD35 sends an event alarm in case the input **has been activated** longer than the preconfigured time.

**Under “Message configuration” you can configure the event messages of your STD35.**

- “Send start-up SMS”:  
This is the same as if you would send the SMS command “S1:x.”  
Here you can switch on or off the Start-SMS (START-UP ALARM). You only have to click on the drop-down menu and selected the desired value (ON = will be sent; OFF = will not be sent)
- “Password”:  
This is the same as if you would send the SMS command “PN:<4-digit password>.”  
This command changes the password of the STD35 The password can include letters and figures but no special characters are allowed. All letters have to be in capital. The standard password (factory setting) is the last 4 digits of the IMEI (see chapter SMS Commands).
- “Message 1 text” and “Message 2 text” or “Power-up message text”:  
This is the same as if you would send the SMS commands “E1:<text1>.”, “E2:<text2>.” and “PT:<startup-text>.”  
You can change the texts of the Start-up alarm and event SMS with these commands. **Do not use command syntax inside a message text. The ‘.’ is the terminating character of the text.** The message length must not exceed 64 characters.

**Under “CLIP configuration” you can configure the important Telephone numbers of your STD35.**

- “Master mobile”:  
Here you enter the phone number of the master mobile telephone.
- “Clip 2 mobile”, “Clip 3 mobile”, “Clip 4 mobile”, “Clip 5 mobile”:  
This is the same as if you would send the SMS command “C2:<number>.”, “C3:<number>.”, “C4:<number>.”, “C5:<number>.”  
Here you can enter up to four additional alarm numbers (=mobile phones) which should receive also the start-up alarm and event SMS. These phone numbers are also allowed to switch relay 1 via call but they cannot change the configuration of the device via SMS (C2:–C5:).  
In case the alarm numbers are entered in international format they have to start with ‘+’ (e.g. +491721234567)

**Under “Web authorization” you can configure the access data for the web interface**

- “Web access user name”  
Here you change the user name
- “Web access password”  
Here you change the password

At the end you have to confirm your settings with the “Accept”-Button.

## 9.6 “Advanced Configuration”-Page

To make the additional configuration settings (as described in chapter 8.2) you have to click on the “Advanced Configuration”-Page.

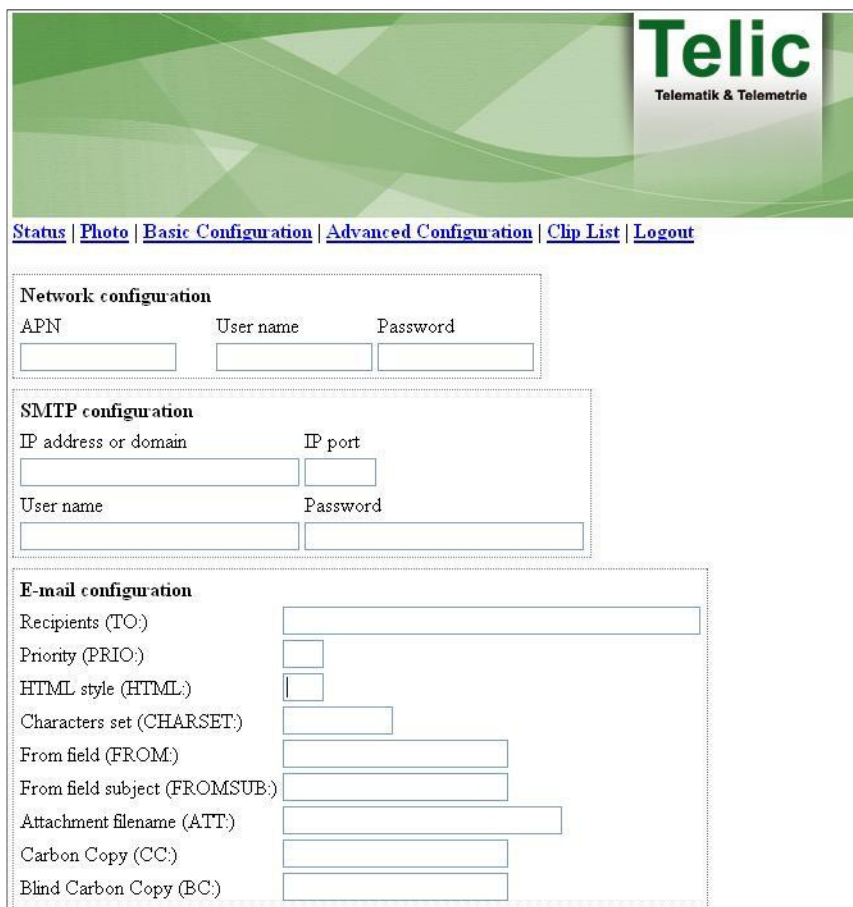

**Network configuration**

APN  User name  Password

**SMTP configuration**

IP address or domain  IP port

User name  Password

**E-mail configuration**

Recipients (TO:)

Priority (PRIO:)

HTML style (HTML:)

Characters set (CHARSET)

From field (FROM)

From field subject (FROMSUB)

Attachment filename (ATT)

Carbon Copy (CC)

Blind Carbon Copy (BC)

In the upper part of the “Advanced Configuration”-Page you can change the GPRS and e-mail settings.

### Under “Network configuration” you can make the GPRS settings of your STD35.

This is the same as if you would send the SMS command “APN:<text>”, “APNUSR:<text>”, “APNPWD:<text>”. These are the basic settings to build up a GPRS (internet) connection. Enter the name of your APN in “APN”, the user name in “User name” and the password in “Password”.

Your GSM network provider will give you the necessary data you need.

### Under “SMTP configuration” you can make the SMTP (e-mail) settings of your STD35.

This is the same as if you would send the SMS command “SMTPIP:<text>”, “SMTPPORT:xxxxx.”, “SMTPUSR:<text>” and “SMTPPWD:<text>”.

Here you make the configuration settings of the SMTP server.

Enter your IP address of your SIM card at “IP address or domain”, the port at “IP Port”, your user name at “User name” and your password at “Password”.

Your SMTP service provider will give you the necessary data you need.

### Under “E-mail configuration” you can make the e-mail settings of your STD35.

- “Recipients”:

This is the same as if you would send the SMS command “TO:<text>”.

You can list up to 5 e-mail addresses each separated by a <;>. The max. length per e-mail address is 75 characters. Default status: no e-mail address is entered. In case of the following events an e-mail will be sent: Start Up, Input1, Input2, incoming call or when a camera picture is triggered via SMS or call.

- “Priority”:  
This is the same as if you would send the SMS command “PRIO:<x>.”  
This command sets the priority with which the e-mail will be displayed. Possible values are from 1 to 5. The default value is 3 (normal priority).
- “HTML style”:  
This is the same as if you would send the SMS command “HTML:<x>.”  
Here you can define whether the e-mail should be sent as a HTML message or as a text message (1 = HTML and 0 = text). The default value is 0.
- “Characters set”:  
This is the same as if you would send the SMS command “CHARSET:text>.”  
Here you define with which coding you want to send the e-mail. The default value is "UTF-8". Normally you do not have to change this.
- “FROM field”:  
This is the same as if you would send the SMS command “FROM:<text>.”  
Here you can configure the sender e-mail address. The maximum length is 75 characters. The default value is [noreply@telic.de](mailto:noreply@telic.de)
- “FROM field subject”:  
This is the same as if you would send the SMS command “FROMSUB:<text>.”  
If you want to enter the sender into the subject line you have to set this command. The maximum length is 75 characters. No sender e-mail address is entered here as default value.
- “Attachment file name”:  
This is the same as if you would send the SMS command “ATT:<x>.”  
Here you can mention the name of the attachment.
- “Carbon Copy”:  
This is the same as if you would send the SMS command “CC:<text>.”  
If you want to put a recipient in CC (Carbon Copy) you can use the above command. The max. length is 75 characters. No CC e-mail address is entered here as default value.
- “Blind Carbon Copy”:  
This is the same as if you would send the SMS command “BC:<text>.”  
If you want to put a recipient in BCC (Blind Carbon Copy) you can use the above command. The maximum length is 75 characters. No BCC e-mail address is entered here as default value.

In case you want to send some event messages only to certain e-mail recipients or if you want to change the standard message you can do this via the "Advanced configuration"- Page for the individual events.



[Status](#) | [Photo](#) | [Basic Configuration](#) | [Advanced Configuration](#) | [Clip List](#)  
[Documentation DE](#) | [Documentation EN](#)

#### Network configuration

APN	User name	Password
<input type="text" value="cda.vodafone.de"/>	<input type="text" value="...@mdex.d"/>	<input type="password" value="....."/>

#### SMTP configuration

IP address or domain	IP port
<input type="text" value="auth.smtp.configtools.de"/>	<input type="text" value="25"/>
User name	Password
<input type="text" value="std32@telic.de"/>	<input type="password" value="....."/>

#### E-mail configuration

Recipients (TO:)	<input type="text" value="...@cetec.cc"/>
Priority (PRIO:)	<input type="text" value="3"/>
HTML style (HTML:)	<input type="text" value="1"/>
Characters set (CHARSET:)	<input type="text" value="UTF-8"/>
From field (FROM:)	<input type="text" value="std32@telic.de"/>
From field subject (FROMSUB:)	<input type="text"/>
Attachment filename (ATT:)	<input type="text" value="photo.jpg"/>
Carbon Copy (CC:)	<input type="text"/>
Blind Carbon Copy (BC:)	<input type="text"/>

#### Event 1 (Input 1 alarm) e-mail

Recipients for this event only (TO1:)	<input type="text" value="...@cetec.cc"/>
Subject (SUB1:)	<input type="text" value="blub"/>

<b>Event 2 (Input 2 alarm) e-mail</b>	
Recipients for this event only (TO2:)	<input type="text" value="sepp@meier.de"/>
Subject (SUB2:)	<input type="text" value="STD35 input 2 alarm"/>
<b>Event 3 (Input 3 alarm) e-mail</b>	
Recipients for this event only (TO3:)	<input type="text" value="sepp@meier.de"/>
Subject (SUB3:)	<input type="text" value="STD35 input 3 alarm"/>
<b>Event 4 (Input 4 alarm) e-mail</b>	
Recipients for this event only (TO4:)	<input type="text" value="sepp@meier.de"/>
Subject (SUB4:)	<input type="text" value="STD35 input 4 alarm"/>
<b>Event 5 (Input 5 alarm) e-mail</b>	
Recipients for this event only (TO5:)	<input type="text" value="sepp@meier.de"/>
Subject (SUB5:)	<input type="text" value="STD35 input 5 alarm"/>
<b>Event 6 (Startup alarm) e-mail</b>	
Recipients for this event only (TO6:)	<input type="text" value="sepp@meier.de"/>
Subject (SUB6:)	<input type="text" value="STD35 startup alarm"/>
<b>Event 7 (Incoming call) e-mail</b>	
Recipients for this event only (TO7:)	<input type="text" value="sepp@meier.de"/>
Subject (SUB7:)	<input type="text" value="STD35 call alarm"/>
<b>Event 8 (Photo) e-mail</b>	
Recipients for this event only (TO8:)	<input type="text" value="hello@world.glo"/>
Subject (SUB8:)	<input type="text" value="STD35 photo"/>
<b>Event 9 (Motion) e-mail</b>	
Recipients for this event only (TO9:)	<input type="text" value="sepp@meier.de"/>
Subject (SUB9:)	<input type="text" value="STD35 motion event"/>
<b>Event 10 (Stationary) e-mail</b>	
Recipients for this event only (TO10:)	<input type="text" value="sepp@meier.de"/>
Subject (SUB10:)	<input type="text" value="STD35 stationary event"/>

**“Event 1 (input 1 event) e-mail”:**

- “Recipients for this event only (TO1)”  
Here you define the recipient e-mail address (**only for event 1**). You can list up to 5 e-mail addresses each separated by a <>. The maximum length per e-mail address is 75 characters. Default status: no e-mail address is entered.
- “Subject”  
Here the subject line of the e-mail is defined. The maximum length is 128 characters per text.

**“Event 2 (input 2 event) e-mail”:**

- “Recipients for this event only (TO2)”

Here you define the recipient e-mail address (**only for event 2**). You can list up to 5 e-mail addresses each separated by a <>. The maximum length per e-mail address is 75 characters. Default status: no e-mail address is entered.

- “Subject”

Here the subject line of the e-mail is defined. The maximum length is 128 characters per text.

**“Event 3 (input 3 event) e-mail”:**

- “Recipients for this event only (TO3)”

Here you define the recipient e-mail address (**only for event 3**). You can list up to 5 e-mail addresses each separated by a <>. The maximum length per e-mail address is 75 characters. Default status: no e-mail address is entered.

- “Subject”

Here the subject line of the e-mail is defined. The maximum length is 128 characters per text.

**“Event 4 (input 4 event) e-mail”:**

- “Recipients for this event only (TO4)”

Here you define the recipient e-mail address (**only for event 4**). You can list up to 5 e-mail addresses each separated by a <>. The maximum length per e-mail address is 75 characters. Default status: no e-mail address is entered.

- “Subject”

Here the subject line of the e-mail is defined. The maximum length is 128 characters per text.

**“Event 5 (input 5 event) e-mail”:**

- “Recipients for this event only (TO5)”

Here you define the recipient e-mail address (**only for event 5**). You can list up to 5 e-mail addresses each separated by a <>. The maximum length per e-mail address is 75 characters. Default status: no e-mail address is entered.

- “Subject”

Here the subject line of the e-mail is defined. The maximum length is 128 characters per text.

**“Event 6 (start up alarm) e-mail”:**

- “Recipients for this event only (TO6)”

Here you define the recipient e-mail address (**only for event 6**). You can list up to 5 e-mail addresses each separated by a <>. The maximum length per e-mail address is 75 characters. Default status: no e-mail address is entered.

- “Subject”

Here the subject line of the e-mail is defined. The maximum length is 128 characters per text.

**“Event 7 (incoming call) e-mail”:**

- “Recipients for this event only (TO7)”

Here you define the recipient e-mail address (**only for event 7**). You can list up to 5 e-mail addresses each separated by a <>. The maximum length per e-mail address is 75 characters. Default status: no e-mail address is entered.

- “Subject”

Here the subject line of the e-mail is defined. The maximum length is 128 characters per text.

**“Event 8 (photo) e-mail”:**

- “Recipients for this event only (TO8)”

Here you define the recipient e-mail address (**only for event 8**). You can list up to 5 e-mail addresses each separated by a <>. The maximum length per e-mail address is 75 characters. Default status: no e-mail address is entered.

- “Subject”

Here the subject line of the e-mail is defined. The maximum length is 128 characters per text.

**“Event 9 (motion) e-mail”:**

- “Recipients for this event only (TO9)”

Here you define the recipient e-mail address (**only for event 9**). You can list up to 5 e-mail addresses each separated by a <;>. The maximum length per e-mail address is 75 characters. Default status: no e-mail address is entered.

- “Subject”

Here the subject line of the e-mail is defined. The maximum length is 128 characters per text.

**“Event 10 (stationary) e-mail”:**

- “Recipients for this event only (TO10)”

Here you define the recipient e-mail address (**only for event 10**). You can list up to 5 e-mail addresses each separated by a <;>. The maximum length per e-mail address is 75 characters. Default status: no e-mail address is entered.

- “Subject”

Here the subject line of the e-mail is defined. The maximum length is 128 characters per text.

After that you have to confirm your settings with “Accept”.

**To set the STD35 back to factory settings please click on the Page “Advanced Configuration” and then on “Reset” at the bottom under “Misc configuration”.**



**Please note that this will delete all previously made configuration settings!**

## 9.7 “Clip List”-Page

You can authorize up to 500 phone numbers to switch relay 1 via call.

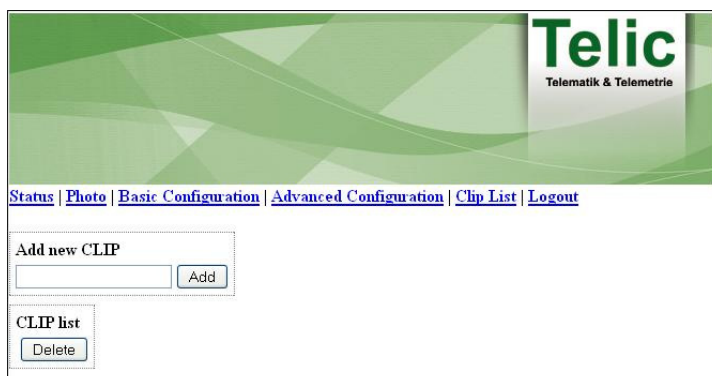

### “Add new CLIP”

This is the same as if you would send the SMS command “CL:<number>.” Enter the phone number into the text field and confirm with the “Add”-button.

### “CLIP list”

Under “CLIP list” all phone numbers will be listed which you have added to the clip list.

In case you want to delete a phone number you only have to click on the “Delete”-button behind the respective phone number. This is the same as if you would send the SMS command “CD:<number>.”

## 9.8 “Logout”-Page

After you have made all settings please click on “Logout” to check out and to leave the web interface. Only then you can be make sure that no unauthorized people make changes to your STD35 configurations.

## 9.9 Detailed example

You want to configure a STD35. The Output 1 should switch for 10 seconds after an incoming call/SMS/internet command. Additionally you want to authorize a telephone number in international format to switch Relay 1 via SMS (+491721234567; example for a German phone number). Another phone number (01529876543) should be allowed to switch Relay 1 via call.

In case of an alarm (Event 1 to 4) an e-mail should be sent to erika.muster@muster.de and karl.muster@test.de. You want that in case of Event 1 (and only then) an e-mail will be sent to peter.mustermann@muster.de.

The e-mail of Event 1 should look like this:

Subject: Power failure

Body: Fridge out of order

### **your GSM Provider APN user settings (from GSM network operator):**

APN: web.vodafone.de

User: vodafone

Passwort: vodafone

### **your SMTP email settings (from email provider):**

Servename: smtp.de.aol.com

Serverport: 25

Username: Hans.Muster

Passwort: Muster

**The password for the STD35 (last for numbers of the IMEI) is 4244**

**The administrators telephone number is: 0164 111 222 3**

## 9.10 Configuration via SMS

- **1.SMS (“Basic Configuration”)**

4244 O1:10.C2:+491721234567.CL:+491529876543.

- **2. SMS (GPRS settings)**

4244 APN:"web.vodafone.de".APNUSR:vodafone.APNPWD:vodafone.

- **3. SMS (SMTP settings)**

4244 SMTPIP:"smtp.de.aol.com".SMTPPORT:25.SMTPUSR: "Hans.Muster". SMTPPWD:Muster.

- **4. SMS (E-mail settings 1)**

4244 TO: "erika.muster@muster.de"."karl.muster@test.de".

- **5. SMS (E-mail settings 2)**

4244 TO1: "peter.mustermann@muster.de".

- **6. SMS (E-mail settings 3)**

4244 SUB1:Power failure.BODY1:Fridge out of order.

## 9.11 Configuration via web interface

- Enter the IP address of your STD35 via standard web browser (e.g. Internet Explorer or Firefox) and Page yourself (see chapter 9.2)
- Open the “Basic Configuration”-Page and make the following settings (M1 and C2 need to correspond with your mobile devices):

The screenshot shows the Telic web interface with the following configuration sections:

- IOs configuration:** Output 1 time (10), Output 2 time (1), Input 1 delay (1), Input 2 delay (1), Input 1 debounce (1), Input 2 debounce (1), Invert input 1 (inverted), Invert input 2 (inverted).
- Message configuration:** Send start-up SMS (ON), Password, Message 1 text, Message 2 text, Power-up message text.
- CLIP configuration:** Master mobile (M1) (01641112223), Clip 2 mobile (C2) (+491234567), Clip 3 mobile (C3), Clip 4 mobile (C4), Clip 5 mobile (C5).
- Web authorization:** Web access user name, Web access password.

An "Accept" button is located at the bottom of the form.

Confirm with “Accept”.

- Open “Advanced Configuration”-Page and configure the email address and a subject for Event 1

Confirm with “Accept”.

- Open “Clip List” and make the following settings:



Click on "Add"

## 10 Connecting the camera

The STD35 offers the possibility to monitor an object or a room with the help of the Telic camera optional accessory for the STD35. You can retrieve an actual picture from the STD35 using any computer worldwide that is connected to the internet (e.g. to check the weather conditions at your holiday home).

In addition a picture can be sent as an attachment to the preconfigured e-mail address in the case of an alarm. This allows you to take further action if necessary (e.g. call the police if you see a burglar on the photo)

To be able to use this functionality you only have to connect the Telic camera to the camera plug on the STD35 (see picture 1).

After the software of the STD35 has recognized the camera the pictures can be viewed or sent via e-mail in the following ways:

- Access of the web-browser through the internet and click on "Photo"-Page (see chapter 0)
- E-mail with JPEG attachment in alarm situation (see chapter 8.1)
- E-mail with JPEG attachment after incoming call (see chapter 8.2)
- E-mail with JPEG attachment after SMS request (see chapter 8.2)

In case the light intensity is not enough at the survey area the infrared light of the camera will be activated automatically. Please note that due to the infrared light there will be a loss of colours in the picture.

The Telic camera has an adjustable sun shade (metal plate over the camera). Please take into consideration when adjusting the sun shade that the shadows are often changing during the day.

**TIP:** To make sure that all desired objects will be in the picture, that the sun shade is in a good position and/or that the illumination of the room will lead to satisfactory picture we recommend to take "test pictures" after the installation. Only then you can rely on the full functionality of the Telic camera.

## 11 Configuration Tool

Besides configuring The STD35 via SMS, Webserver or using a configuration call it is possible to use the Telic configuration tool to implement all setting. This tool allows the user to connect the device to a standard PC via a special STDx accessory cable.

Once the cable is connected the STD35 can be monitored and completely configured using the software provided. The configuration tool allows the user to configure devices without having to manually construct SMS commands or send any SMS to the device. You will get further information via [info@telic.de](mailto:info@telic.de).

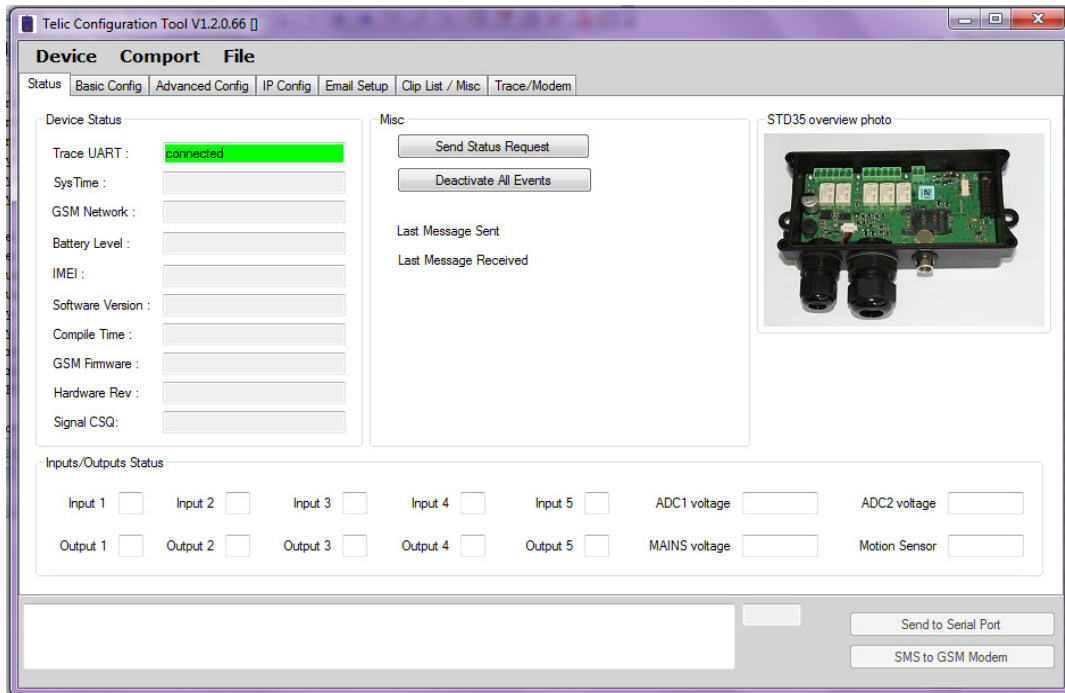

## 12 Troubleshooting

<b>Problem</b>	<b>Possible Reason</b>	<b>Solution</b>
GSM LED stays dark	No supply voltage-	Connect power supply
GSM LED blinks twice cyclically	No SIM card / Improper contact with SIM card	Insert SIM card properly or carefully clean contact area of SIM card
GSM LED blinks thrice cyclically	PIN is not "0000" or "2468"	Change SIM card's PIN to "0000" or "2468"
GSM LED constantly on	No GSM network available / no antenna connected	Connect antenna / Change antenna position
GSM LED dies after 3 minutes	No configuration	Make configuration call
STD35 does not react on configuration call (not accepting the call)	Device is already configured	Set back to factory settings
STD35 does not react to a configuration SMS	Wrong IMEI number in the SMS / SMS not yet delivered	Check IMEI number. / Wait until SMS is delivered
STD35 does not react to an SMS, or call, although booked to the network	The mobile phone does not transmit the phone number ("Incognito")	Activate the transmission of the phone number in your mobile phone
System LEDs toggle	No configuration call received by STD35	Make configuration call

## 13 Wiring examples

### 1. Alarm message when power supply is connected through sensor or switching contact

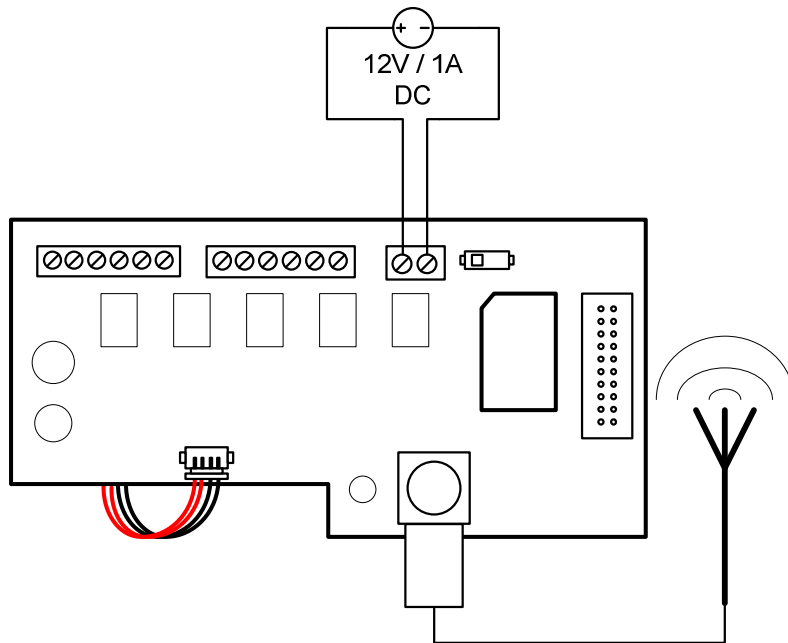

Connect the STD35 to a 12V power supply and you will receive a SMS on your mobile phone (or an e-mail to the preconfigured e-mail address) as soon as the device is booked into the GSM network. The message type is the Start-up alarm message. The power supply can be provided e.g. by a door contact or another alarm sensor.

### 2. Remote switching of electric devices via voice call or SMS

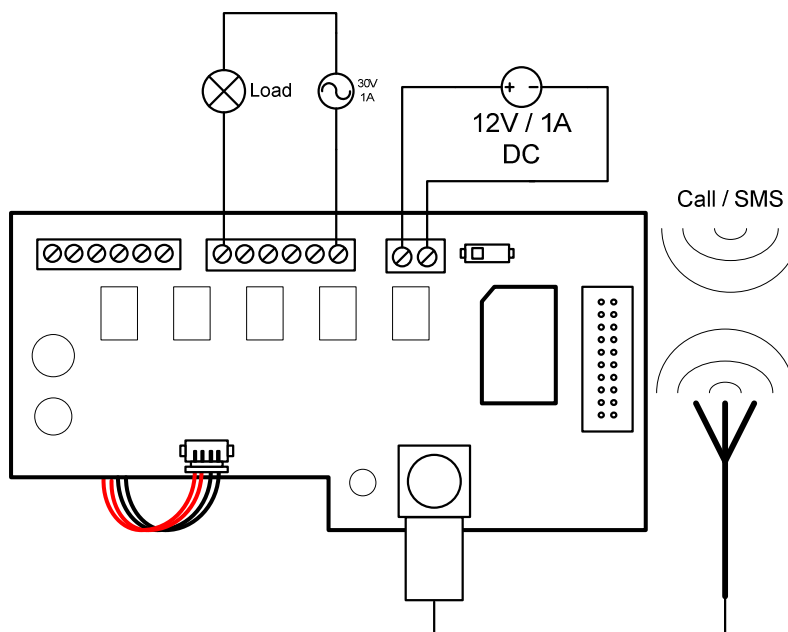

Call the configured STD35 with your mobile phone or send a SMS command and you can switch any electric device up to 30V / 1A (e.g. heating system, air condition, alarm system, garage door etc.).

### 3. Sensor / alarm message via SMS / e-mail as soon as an input is supplied with 12V

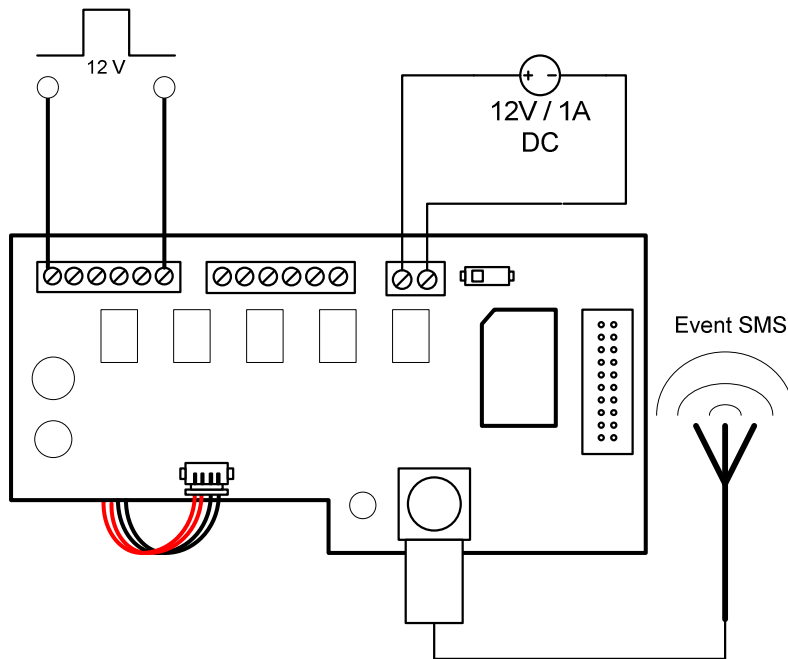

Connect one input of the configured STD35 with 12V power supply and you will get an alarm SMS to your mobile phone or an alarm e-mail to the preconfigured e-mail address (e.g. triggered by an existing alarm system, infrared sensor, temperature sensor, fluid level sensor, door contact etc.).

### 4. Remote switching of electric devices which are connected to the power supply via voice call or SMS

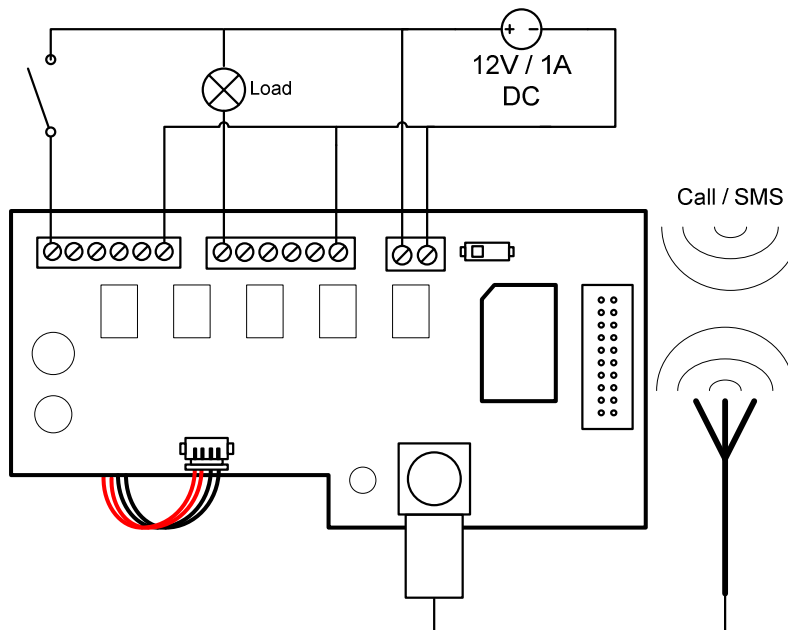



Call the configured STD35 with your mobile phone or send a SMS command and you can switch an electronic device which uses the connected power supply voltage.

## 14 Accessories

Telic GmbH is offering accessory parts for the STD35 which have been thoroughly tested to work with the STD35 and which have been approved for the use with the STD35. Therefore we strongly recommend to use only accessory parts of Telic GmbH. The warranty will be null and void if you use other than the original Telic accessory parts.

Please contact your supplier or Telic GmbH regarding the original accessory parts. The recommended accessory parts mainly consist of :

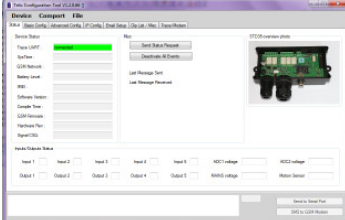
<p><b>GSM-magnetic antenna</b>  <b>- Part-Number 12001-</b>          FME-female connector and 2.5m cable</p>	
<p><b>GSM-roof mount antenna</b>  <b>- Part-Number 12006-</b>          FME-female connector,          3m cable, waterproof</p>	
<p><b>Telic Camera</b>  <b>- Part-Number 14005-</b>          Camera with plug for STD35 and 2.5 m          cable (incl. infrared-light for photos in          dark environment)</p>	
<p><b>Configuration Tool &amp; Cable</b>  <b>- Part-Number 16203 -</b>          STD35 accessory connector</p>	

## 15 Technical data

- GSM: Quad Band EGSM 850/900/1800/1900 MHz  
Compatible with ETSI GSM Phase 2+ Standard
- Output power:  
Class 4 (2W @ 850/900 MHz)  
Class 1 (1W @ 1800/1900 MHz)
- Temperature range: -30°C - +75°C
- Weight approx. 220 grams
- Dimensions: 150x65x45 mm (l x w x h)
- Supply voltage: 7-32V
- Idle current: 34mA, peak up to 1A
- Max. output current: 2A  
Max. output voltage: 30V AC
- Input voltage (digital inputs)  
logic 1 (threshold >7V): max 32V  
logic 0 (threshold <1,5V): min 0V
- Input voltage (analog inputs)  
Max (32V)  
Min (0V)

In case of technical problems or questions concerning the STD35 our hotline is available for you:

Monday – Friday: 9 am – 12am and 1pm – 5pm  
Technical Hotline: +49 (0)89 / 4902686-11  
Email-Support: support@telic.de

For all other questions please call

Sales: +49 (0)89 / 4902686-0

## 16 Document history

Revision	Datum	Changes
Rev. 1.0	16 <sup>th</sup> Dec 2010	Original file
Rev.1.1	14 <sup>th</sup> Jan 2011	Update
Rev 1.2	23 <sup>rd</sup> Jan 2011	Added Configuration Tool
Rev 1.3	6 <sup>th</sup> June 2011	Minor Corrections
Rev 1.4	9 <sup>th</sup> June 2011	Corrected relay voltage mistake

### Imprint

These operating instructions are published by Telic GmbH

No reproduction (including translation) is permitted in whole or part e.g. photocopy, microfilming or storage in electronic data processing equipment, without the express written consent of the publisher.

The operating instructions reflect the current technical specifications at time of print.

We reserve the right to change the technical or physical specifications.

© Copyright 2011 by Telic GmbH – printed in Germany

Telic GmbH  
Raiffeisenallee 12b  
D-82041 Oberhaching  
Germany  
[www.telic.de](http://www.telic.de)

Telic reserves the right to change, correct and/or improve the content any time and without prior notice without being obliged to do so. No responsibility is taken for the correctness of the information.