

HT63 E Terminal User Manual

Revision 1.3



Important information

This technical description contains important information for start up and use of the HT63 E Terminal. Read it carefully before you start working with the HT63 E Terminal.

The warranty will be void should damage occur due to non-compliance with these instructions for use. We cannot accept any responsibility for consequential loss.

We cannot be held responsible for material loss or personal injury that is due to incompetent use or non-compliance with the safety instructions. The warranty will be void in such circumstances.

The HT63 E Terminal contains highly integrated components which can be damaged by electrostatic discharge if the user would open the housing.

CEP preserves the right to change the included information without notice and doesn't take responsibility for errors in the document and/or missing information.

	Therefore only touch the HT63 E Terminal on the housing or connectors and avoid touching the components on the board.
--	---

Safety Instructions

	When using products which are exposed to electric voltage the valid regulations have to be observed.
---	--

Before opening of a device always pull the mains adapter or make sure that the device is disconnected from the power supply.

You should only use tools on components, modules or devices if they are disconnected from the power supply and the electric charge, which may still be stored in some components, inside the device has been discharged.

All cables and wires which are energized and connected to the device, the module or components have to be checked regularly for any damage of the isolation shield or fractures of the cables. If the supply cables are visibly damaged the device has to be taken out of operation immediately until the faulty cable has been exchanged.

When using components or modules it is necessary to strictly observe the specification given in the corresponding description of these components. If a description for a private end-customer not clearly states which electric data is valid for a component or a module, how to wire the

device, which external components or additional devices can be connected or which parameters these components are allowed to have, a specialist must be contacted.

Before putting a device into operation, it has to be clarified, whether this device or module is meant for the field of application. In case of doubt ask specialists or the manufacturer of the device.

Please note that we are not responsible for any errors in usage or connection. Therefore we cannot accept any responsibility for consequential loss.

Devices which operate with >35 Volt have to be connected by a specialist. Before putting the device into operation it should be checked that there is no current leakage on the housing.

In case those measurements with the opened housing are necessary, an isolating-transformer has to be integrated for safety reasons. Alternatively the voltage can be supplied by an appropriate power supply which complies with the safety regulations. All wiring work has to be done in a voltage free state only.

Table of Contents

Important information	2
Safety Instructions.....	2
1 Mechanical Description	7
1.1 Overview	7
1.2 Physical Dimension and Weight.....	8
2 Electrical Description	9
2.1 Power Connector	9
2.2 Antenna Connector	10
2.3 SIM card reader.....	11
2.4 RS232 Serial Port.....	11
2.5 Serial Data	12
2.6 Serial Data Signals.....	12
2.7 Control Signals RTS, CTS, DTR, DSR, DCD, RI.....	12
2.8 Mini USB Connector	13
3 Operation	14
3.1 Switching ON the modem.....	14
3.2 Switching OFF the modem.....	15
3.3 Using low power mode of the modem	15
3.3.1 Enabling the low power mode:	15
3.3.2 Disabling the low power mode by user:.....	15
3.3.3 Disable the low power modes by incoming GSM activity:	15
3.4 Operating states / LEDs	15
4 Power consumption	17
4.1 Safety instruction.....	17
4.2 General precautions	17
4.3 SIM card precautions	18
4.4 Antenna precautions	18
5 Getting started / Installation	19
5.1 Where to install the modem.....	19
5.1.1 Environmental conditions.....	19
5.1.2 GSM Signal strength.....	19
5.1.3 Connections of components to HT63 E Terminal	19
5.1.4 Network and Subscription	20
5.2 How to install the modem.....	20

5.2.1	Power supply	20
5.2.2	Securing the modem	20
5.3	Antenna.....	20
5.3.1	General	20
5.3.2	Antenna type.....	21
5.3.3	Antenna placement	21
5.3.4	The antenna cable	21
5.3.5	Possible communications disturbances	21
6	Optional variants.....	23
7	Technical Data	24
8	CEP Certified Accessories	26
9	Abbreviations.....	27
10	Mark of Conformity	28
11	Service and Support.....	29
12	Documentation Change Log	30

Table Overview

Table 1: Pin Description	10
Table 2: RJ11 Pin and Signals Description.....	10
Table 3: Recommended antenna parameters	11
Table 4: Electrical characteristics of the serial port signals.....	11
Table 5: Mini USB Pin Description.....	13
Table 6: Operating states of the power up LED	16
Table 7: Power consumption in idle and low power mode.....	17
Table 8: Accessories List	26
Table 9: Abbreviation	27
Table 10: Documentation Change Log	30

Figure Overview

Figure 1: Connectors on rear side of the Terminal	7
Figure 2: Connectors on front side of the Terminal	7
Figure 3: Schematic of the Terminal's Housing	8
Figure 4: RJ11 Pin Connector	9
Figure 5: Mini USB Type A/B connector.....	13

1 Mechanical Description

1.1 Overview

The pictures below show the mechanical design of the HT63-E Terminal along with the positions of the different connectors and mounting holes. The HT63-E Terminal case is made of durable PC/ABS plastic.

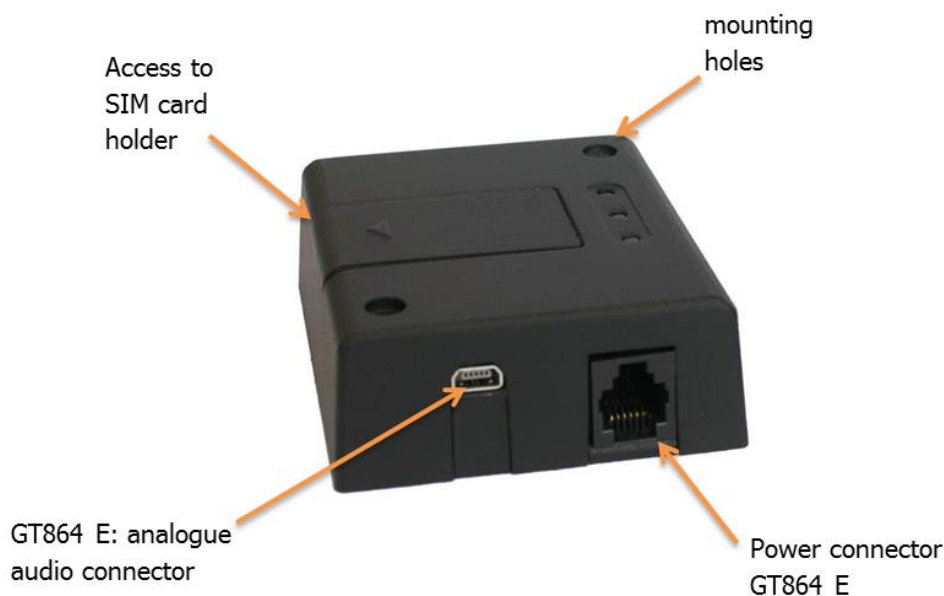

Figure 1: Connectors on rear side of the Terminal

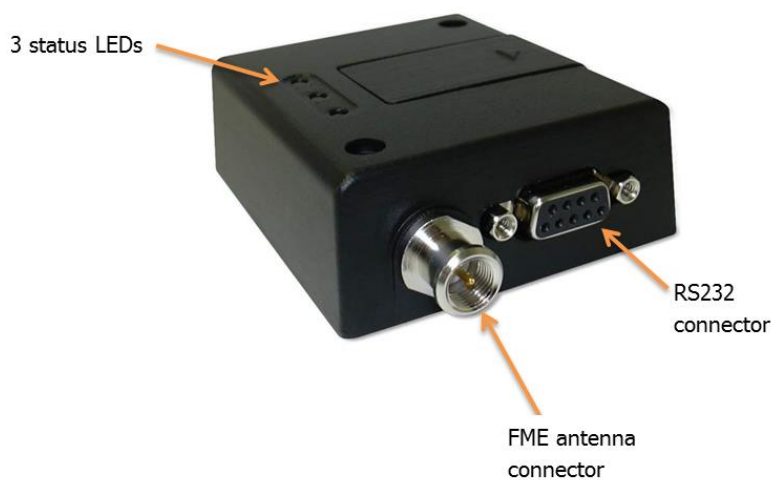

Figure 2: Connectors on front side of the Terminal

Please note the following

- Mounting holes positioned at two of the corners make it possible to securely bolt the modem into your application.
- Keypad, display, microphone, speaker and battery are not part of the modem.
- The SIM card is mounted in the modem, accessible by the user under a lid without any tools.
- The pins and electrical characteristics of the modem's various connectors are described in "2. Electrical Description"
- Information about the antenna connector is found in "2.3 Antenna Connector"

1.2 Physical Dimension and Weight

Overall dimensions: 77 x 67 x 26 mm

Weight: approx. 100g

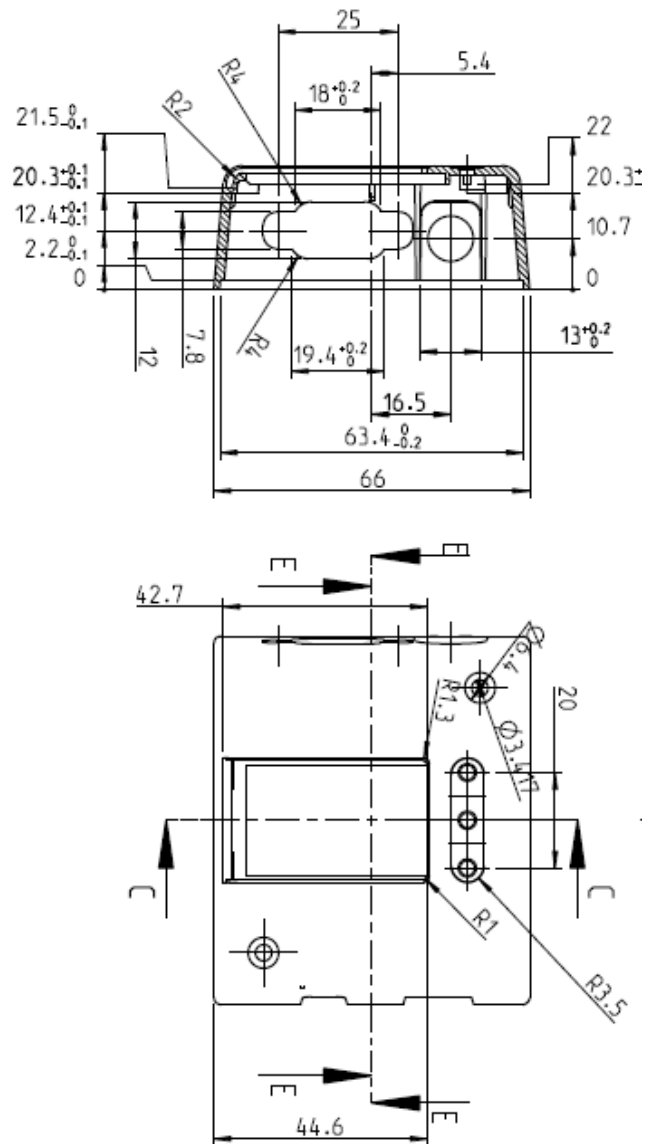
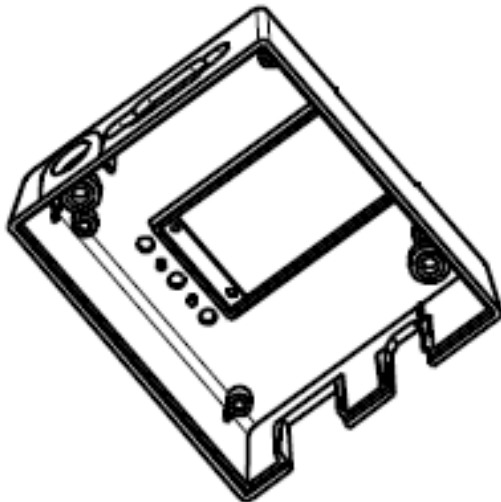
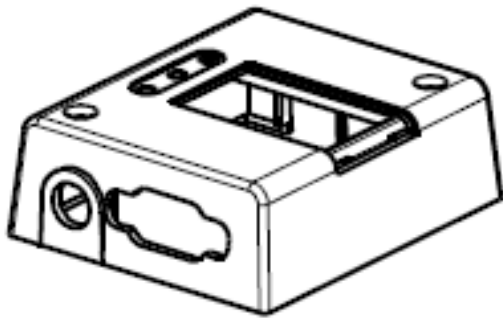

Figure 3: Schematic of the Terminal's Housing

2 Electrical Description

The modem uses the following standard connectors:

- RJ11 6-way (power connector)
- Mini USB (USB 2.0)
- SIM card reader
- FME male coaxial jack (antenna connector)
- Sub-D female socket, 9 pin (RS232 serial port)

2.1 Power Connector

An RJ11 6-way connector, as shown and described below, serves as a means of supplying and controlling DC power to the modem. It is necessary to connect an external power supply, since the available power on the USB port is not sufficient to run the modem.

The supply voltage, VCC, required by the modem is 5V - 32V DC. Application of the supply voltage does not switch the modem on. To do so an additional active-high control signal, TO_IN, must be applied for > 1 second.

Please see chapter "3.1 Switching ON the modem" for further important details about TO_IN and power supply requirements, especially if TO_IN is applied in parallel to VCC.

VCC and GND are reverse-polarity and over-voltage protected.



This does not apply for the GND on the antenna connector if this coax GND / shield are connected to your applications ground-plane.

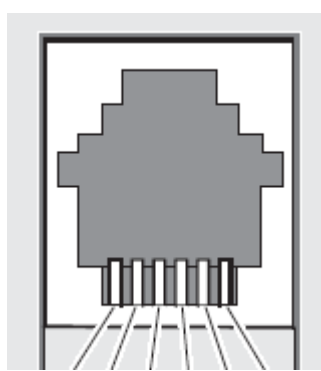

PIN 6 5 4 3 2 1

Figure 4: RJ11 Pin Connector

Pin	Description
1	VCC
2	-
3	EMERG_OFF
4	TO_IN
5	-

Table 1: Pin Description

PIN	Signal	Direction	Limits	Description
1	VCC	Input	5 – 32V	Positive power input, DC
2	Not connected	Not connected	Not connected	Not connected
3	EMERG_OFF	Input	5 – 32V	Active high control line used to switch off $V_{IH} > 5V$, $V_{IL} < .5V$ Power off: $t > 1s$
4	TO_IN	Input	5 – 32V	Positive edge triggered signal; used to switch on the modem $V_{IH} > 5V$, $V_{IL} < 0.5V$ Power on: $t > 1s$
5	Not connected	Not connected	Not connected	Not connected
6	GND	Input	-	Negative power (ground) input and return path for TO_IN and EMERG_OFF

Table 2: RJ11 Pin and Signals Description

2.2 Antenna Connector

The antenna connector allows transmission of radio frequency (RF) signals between the modem and an external customer-supplied antenna. The modem is fitted with a 50Ω, FME male coaxial jack.

Output Power:

2 Watt Peak (Class 4) GSM 900/850 MHz
1 Watt Peak (Class 1) GSM 1800/1900 MHz

The antenna that the customer chooses to use should fulfil the following requirements:

Frequency range	GSM 850/900 MHz GSM 1800/1900 MHz
Bandwidth	80 MHz in EGSM 900, 70 MHz if GSM 850,
Gain	< 3dBi
Impedance	50 ohm
Input power	> 33dBm (2W) peak power in GSM
VSWR recommended	< 2

Table 3: Recommended antenna parameters

2.3 SIM card reader

The HT63-E Terminal is fitted with a SIM card reader designed for 1.8V and for 3V SIM cards. It is the flip-up type which is lockable in the horizontal position and is accessed through a removable panel.

2.4 RS232 Serial Port

The modem supports a standard RS232 serial interface via its 9 pin Sub-D connector, shown below. In line with serial communication terminology the HT63-E Terminal should be considered as the data circuit-terminating equipment (DCE) and the external application or computer as the data terminating equipment (DTE). The maximum baud rate to communicate with the HT63-E Terminal is 230400 kbit/ s.

The electrical characteristics of the serial port signals are shown below:

PIN	Signal	Direction	Voltage levels	Description
1	DCD	Output	> + 4V <- 4 V	Data carrier detect
2	RD	Output	> + 4V <- 4 V	Received data
3	TD	Input	> + 2,4V < 0.8 V	Transmitted data
4	DTR	Input	> + 4V < 0.8 V	Data terminal ready
5	GND	-	0 V	Ground connection
6	DSR	Output	> + 4V < - 4 V	Data set ready
7	RTS	Input	> + 2,4V < 0.8 V	Request to send
8	CTS	Output	> + 4V < - 4 V	Clear to send
9	RI	Output	> + 4V < - 4 V	Ring indicator

Table 4: Electrical characteristics of the serial port signals

2.5 Serial Data

The modem supports the standard data character format of

- Programmable baud rate (300bps to 230,400bps).
- Auto-configuration mode with auto-baud (1,200bps to 230,400bps).
- Multiplex ability according to GSM 07.10 Multiplexer Protocol.

2.6 Serial Data Signals

Serial Data From Modem (RD)

RD is an output signal that the modem uses to send data to the application.

Serial Data To Modem (TD)

TD is an input signal, used by the application to send data to the modem.

2.7 Control Signals *RTS, CTS, DTR, DSR, DCD, RI*

Request to Send (RTS)

RTS is used to condition the DCE for data transmission. The default level is high by internal pull up. The exact behaviour of RTS is defined by an AT command. Software or Hardware control can be selected. Hardware flow is the default control. The application must pull RTS low to communicate with the modem. The modem will respond by asserting CTS low, indicating it is ready for communication.

Clear To Send (CTS)

CTS indicate that the DCE is ready to transmit data. The default level is high. You can define the exact behaviour of CTS through an AT command, and can select software or hardware flow control.

Data Terminal Ready (DTR)

DTR indicates that the DTE is ready to transmit and receive data. It also acts as hardware 'hang-up', terminating calls when switched high. The signal is active low. You can define the exact behaviour of DTR with an AT command. The DTR line can also be used to switch on the modem when activated for 0.2 seconds. The DTR line must be deactivated prior to switching off the modem to ensure it switches off (powers down) correctly.

Data Set Ready (DSR)

An active DSR signal is sent from the modem to the application (DTE) to confirm that a communications path has been established. DSR has two modes of operation, settable using the AT command AT&S.

Data Carrier Detect (DCD)

DCD indicates that the DCE is receiving a valid carrier (data signal) when low. You can define the exact behaviour of DCD with an AT command.

Ring Indicator (RI)

RI indicates that a ringing signal is being received by the DCE when low. You can define the exact behaviour for RI with an AT command.

2.8 Mini USB Connector

The modem supports a standard USB 2.0 Full Speed slave interface interface for AT-commands. The maximum baud rate to communicate with the HT63-E Terminal is up to 12Mbit/s.

Drivers for several operating systems (e.g. Windows Vista, Windows XP or Linux) are available. Please ask us (support@cepag.de).

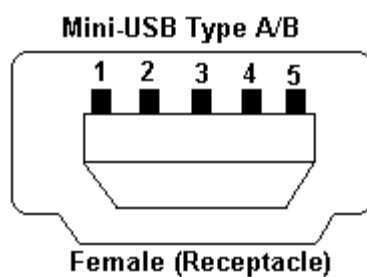

Figure 5: Mini USB Type A/B connector

Pin	Signal
1	VUSB
2	D -
3	D +
4	not connected
5	GND

Table 5: Mini USB Pin Description

3 Operation

3.1 Switching ON the modem

There are two ways to switch on the modem, once power is applied:

- assert TO_IN to high level for > 1s
- activate the RS232 control line DTR

The modem is fully operational after 4 seconds. Logging onto a network may take longer than this and is outside the control of the modem. The modem can be configured to start up at the time power is applied by permanently tying power connector signals TO_IN (pin 4) and VCC (pin 1) together. In this case DTR must be used to switch the modem on again after it has been switched off or reset, while power is still applied.

	DTR must be cycled from low to high.
---	--------------------------------------

	The TO_IN signal requires a positive "edge" (a sharp" signal transition from low to high) to turn the modem on. This transition should be a rising signal from 0V (GND) to VCC, or at least a large fraction of that voltage range, and must be applied at the same time as VCC or after it. Very slow transitions (significantly slower than many milliseconds) or very small transitions (e.g. only few volts instead of 0V to VCC) will not turn on the module (since they are not considered to be a "positive edge").
---	--

Although this will not be an issue in almost all typical applications of the modem, please consider following points:

- Large capacitors in your power supply which will lead to slow leading and falling edges (issue does not apply with modern stabilized switching regulator power-adaptors) AND TO_IN tied in parallel to VCC (instead of separate dedicated digital signal)
- Slow analogue signals used to assert TO_IN
- TO_IN signal not before VCC

All 3 cases above might prevent the modem from recognizing the power-up signal this is no failure of the modem itself, the same would apply to almost any electronic device that provides a separate "power-on" or "reset" signal.

If you are in doubt, please

- Use the mains power adapter that is provided by your distributor and is know to work properly with your modem
- Make sure that your signal and system design is according to the above
- Consult our support team that will be more than happy to assist you.

3.2 Switching OFF the modem

The only way to switch off the modem is to remove the power source.

3.3 Using low power mode of the modem

Below are some short descriptions on how to enter and exit the low power state of the modem.

3.3.1 Enabling the low power mode:

- wait until the GSM module is logged onto the GSM network
- send the AT command "AT+CFUN=9"
- set the RTS control line from High level to Low level
- after about 1-2 minutes, a stable low-power mode should be achieved

3.3.2 Disabling the low power mode by user:

- Set the RTS control line from Low to High
- Low-power mode should be exited automatically
- The RS-232 transceiver is activated immediately
- AT channel is available again after a short period of time (37ms)
- If applicable send AT command "AT+CFUN=1" to remain in normal mode

3.3.3 Disable the low power modes by incoming GSM activity:

- The RTS control line is still at a low level
- GSM module is called or receives an SMS
- Low-power mode is exited automatically
- RS-232 transceiver is activated immediately
- AT channel is available again after 37ms
- If activated by a call the text "ring" is transmitted via the serial interface
- The RTS control line on the DB-9 should be set from Low level to High level
- AT communication with the GSM module is now available
- If applicable send AT command "AT+CFUN =1" to remain in normal mode

3.4 Operating states / LEDs

Power up LED (green LED in the middle)

The modem has a green power up LED, as depicted below, which is used to indicate various operating states. These states are described in following table.

Operating state of HT63-E Terminal	Power up LED state
Device off	Permanently off
net search / not registered /	Fast blinking
registered full service	Slow blinking
A call is active	Permanently on

Table 6: Operating states of the power up LED

4 Power consumption

The following table shows you the power consumption of the HT63 E / in different modes.

	[mA] @ 12V
HT63-E Standby mode	~ 22
HT63-E low power mode	< 2

Table 7: Power consumption in idle and low power mode

Safety and Product Care

Please read the information in this section and the information in "Installation of the Modem", before starting your integration work!

4.1 Safety instruction

PLEASE READ THESE SAFETY INSTRUCTIONS AND KEEP A COPY OF THEM.

- Always ensure that use of the modem is permitted. The modem may present a hazard if used in proximity to personal medical electronic devices. As a rule, the modem must not be used in hospitals, airports or planes.
- Never use the modem at a gas station, refuelling point, blasting area or in any other environment where explosives may be present.
- Operating the modem close to other electronic devices, such as antennas, television sets, and radios may cause electromagnetic interference.
- This product is intended to be used with the antenna or other radiating element at least 20cm away from any part of the human body. In applications where this rule cannot be applied, the application designer is responsible for providing the SAR measurement test report and declaration.
- You are responsible for observing your country's safety standards, and where applicable, the relevant wiring rules.

4.2 General precautions

The HT63-E Terminal as a stand alone item is designed for indoor use only. To use outside it must be integrated into a weatherproof enclosure. Do not exceed the environmental and electrical limits as specified in "Technical Data".

- Avoid exposing the modem to lighted cigarettes, naked flames or to extreme hot or cold temperature.
- Never try to dismantle the modem yourself. There are no components inside the modem that can be serviced by the user. If you attempt to dismantle the modem, you may invalidate the warranty.

- The HT63-E Terminal must not be installed or located where the surface temperature of the plastic case may exceed 85°C.
- All cables connected to the HT63-E Terminal must be secured or clamped, immediately adjacent to the modem's connectors, to provide strain relief and to avoid transmitting excessive vibration to the modem in the installation.
- Ensure the cables, supplying power, audio headset, and input cable to the HT63-E Terminal, does not exceed 3 metres.
- To protect power supply cables and meet the fire safety requirements when the unit is powered from a battery or a high current supply, connect a fast 1.25A fuse in line with the positive supply.
- Do not connect any incompatible component or product to the HT63-E Terminal.



CEP AG may refuse warranty claims where evidence of product misuse is found.

4.3 SIM card precautions

Before handling the SIM card in your application, ensure that you are not charged with static electricity. Use proper precautions to avoid electrostatic discharges.

When the SIM card hatch is opened, the SIM card connectors lie exposed under the SIM card holder.

Caution! Do not touch these connectors! If you do, you may release an electrical discharge that could damage the modem or the SIM card.

When designing your application, the SIM card's accessibility should be taken into account. We always recommend that you have the SIM card protected by a PIN code. This will ensure that the SIM card cannot be used by an unauthorized person.

4.4 Antenna precautions

If the antenna is to be mounted outside, consider the risk of lightning. Follow the instructions provided by the antenna manufacturer.

- Never connect more than one modem to a single antenna. The modem can be damaged by radio frequency energy from the transmitter of another modem.
- Like any mobile station, the antenna of the modem emits radio frequency energy. To avoid EMI (electromagnetic interference), you must determine whether the application itself, or equipment in the application's proximity, needs further protection against radio emission and the disturbances it might cause. Protection is secured either by shielding the surrounding electronics or by moving the antenna away from the electronics and the external signals cable.
- The modem and antenna may be damaged if either come into contact with ground potentials other than the one in your application. Beware, ground potential are not always what they appear to be.

5 Getting started / Installation

This chapter gives you advice and helpful hints on how to integrate the HT63-E Terminal into your application from a hardware perspective. Please read the information given in "Safety and Product Care", page 10 and then read the information in this section before starting your integration work.

5.1 Where to install the modem

There are several conditions which need to be taken into consideration when designing your application as they might affect the modem and its function. They are:

5.1.1 Environmental conditions

The modem must be installed so that the environmental conditions stated in the Technical Data chapter, such as temperature, humidity and vibration are satisfied. Additionally, the electrical specifications in the Technical Data section must not be exceeded.

5.1.2 GSM Signal strength

The modem has to be placed in a way that ensures sufficient GSM signal strength. To improve signal strength, the antenna can be moved to another position. Signal strength may depend on how close the modem is to a radio base station. You must ensure that the location, at which you intend to use the modem, is within the network coverage area. Degradation in signal strength can be the result of a disturbance from another source, for example an electronic device in the immediate vicinity. More information about possible communication disturbances can be found in section 5.3.5.

When an application is completed, you can verify signal strength by issuing the AT command AT+CSQ. See "AT + CSQ Signal Strength".

Tip! Before installing the modem, use an ordinary mobile telephone to check a possible location for it. In determining the location for the modem and antenna, you should consider signal strength as well as cable length

5.1.3 Connections of components to HT63 E Terminal

The integrator is responsible for the final integrated system. Incorrectly designed or installed, external components may cause radiation limits to be exceeded. For instance, improperly made connections or improperly installed antennas can disturb the network and lead to malfunctions in the modem or equipment.

5.1.4 Network and Subscription

Before your application is used, you must ensure that your chosen network provides the necessary telecommunication services. Contact your service provider to obtain the necessary information.

- If you intend to use SMS in the application, ensure this is included in your (voice) subscription.
- Consider the choice of the supplementary services

5.2 How to install the modem

5.2.1 Power supply

- Use a high-quality power supply cable with low resistance. This ensures that the voltages at the connector pins are within the allowed range, even during the maximum peak current.
- When the unit is powered from a battery or a high current supply, connect a fast 1.25A fuse in line with the positive supply. This protects the power cabling and modem.

5.2.2 Securing the modem

Before securing the modem take into account the amount of additional space required for the mating connectors and cables that will be used in the application.

- Where access is restricted, it may be easier to connect all the cables to the modem prior to securing it in the application.
- Securely attach the HT63-E Terminal modem to the host application using two 3mm diameter pan-head screws

5.3 Antenna

5.3.1 General

The antenna is the component in your system that maintains the radio link between the network and the modem. Since the antenna transmits and receives electromagnetic energy, its efficient function will depend on:

- the type of antenna (for example, circular or directional);
- the placement of the antenna;
- Communication disturbances in the vicinity in which the antenna operates.

In the sections below, issues concerning antenna type, antenna placement, antenna cable, and possible communication disturbances are addressed. In any event, you should contact your local antenna manufacturer for additional information concerning antenna type, cables, connectors, antenna placement, and the surrounding area. You should also determine whether the antenna needs to be grounded or not. Your local antenna manufacturer might be able to design a special antenna suitable for the application.

5.3.2 Antenna type

Make sure that you choose the right type of antenna for the modem. Consider the following requirements:

- the antenna must be designed for the one of the frequency bands in use; please ask your network provider for more information:
 - GSM 850/900 MHz
 - GSM 1800/1900 MHz;
- the impedance of the antenna and antenna cable must be 50Ω;
- the antenna output-power handling must be a minimum of 2W;
- the VSWR value should be less than 3:1 to avoid any damage to the modem.

5.3.3 Antenna placement

The antenna should be placed away from electronic devices or other antennas. The recommended minimum distance between adjacent antennas, operating in a similar radio frequency band, is at least 50cm. Therefore we recommend to use a cable antenna and place it away from the terminal. If signal strength is weak, it is useful to face a directional antenna at the closest radio base station. This can increase the strength of the signal received by the modem. The modem's peak output power can reach 2W. RF field strength varies with antenna type and distance. At 10cm from the antenna the field strength may be up to 70V/m and at 1m it will have reduced to 7V/m. In general, CE-marked products for residential and commercial areas, and light industry can withstand a minimum of 3V/m.

5.3.4 The antenna cable

Use 50Ω impedance low-loss cable and high-quality 50Ω impedance connectors (frequency range up to 2GHz) to avoid RF losses. Ensure that the antenna cable is as short as possible. The Voltage Standing-Wave Ratio (VSWR) may depend on the effectiveness of the antenna, cable and connectors. In addition, if you use an adapter between the antenna cable and the antenna connector, it is crucial that the antenna cable is a high-quality, low-loss cable. Minimize the use of extension cables, connectors and adapters. Each additional cable, connector or adapter causes a loss of signal power.

5.3.5 Possible communications disturbances

Possible communication disturbances include the following:

- **Noise** can be caused by electronic devices and radio transmitters.
- **Path-loss** occurs as the strength of the received signal steadily decreases in proportion to the distance from the transmitter.
- **Shadowing** is a form of environmental attenuation of radio signals caused by hills, buildings, trees or even vehicles. This can be a particular problem inside buildings, especially if the walls are thick and reinforced.
- **Multi-path** fading is a sudden decrease or increase in the signal strength. This is the result of interference caused when direct and reflected signals reach the antenna simultaneously. Surfaces such as buildings, streets, vehicles, etc., can reflect signals.

- **Hand-over** occurs as you move from one cell to another in the GSM network. Your mobile application call is transferred from one cell to the next. Hand-over can briefly interfere with communication and may cause a delay, or at worst, a disruption.

6 Optional variants

Optional variants are available:

- I2C/SPI on 15-pin connector
- USB host powered version

Please contact your distributor or CEP AG directly for further information if necessary.

7 Technical Data

Product features:

- Dual Band UMTS 900/2100 MHz
- Dual Band GSM 850/1800
- Control via AT commands according to Hayes 3GPP TS 27.007, 27.005 and proprietary Cinterion
- SIM Access Profile
- Supply voltage range: 5 – 32 V/DC
- TCP/IP stack access via AT commands
- Sensitivity:
 - -107 dBm (typ.)@ 850/900 MHz
 - -106 dBm (typ.)@ 1800/1900 MHz
- Overall dimensions (excluding connectors): 77 x 67 x 26mm
- Weight: ca. 100g
- RoHS compliant
- Temperature range:
 - -40°C to +80°C (Operational)
 - -40°C to +85°C (Storage temperature)

Interfaces:

- Sub-D female 9 pin connector for RS232 communication
- Multiplexer according 3GPP TS 27.010
- USB interface supports multiple composite mode and a Linux/Mac mode
- RJ11: Power: 5 – 32 Volt / DC
- Antenna: 50 Ohm (FME male)
- SIM card reader: 3V interface
- Mini USB Interface

Approvals:

- Full type approved conforming with R&TTE directive
- CE approval

SMS:

- Point-to Point mobile originated and mobile terminated SMS
- Concatenated SMS supported
- SMS cell broadcast
- Text and PDU mode

Circuit switched data transmission:

- Asynchronous circuit switched Data (CSD) up to 9,6 kbps

Wireless Data:

- HSDPA Cat.8 / HSUPA Cat.6 data rates
- DL: max. 7.2 Mbps, UL: max. 5.76 Mbps
- EDGE Class 12 data rates
- DL: max. 237 kbps, UL: max. 237 kbps
- GPRS Class 12 data rates
- DL: max. 85.6 kbps, UL: max. 85.6 kbps

GSM supplementary:

- Call forwarding

- Call barring
- Call waiting and hold
- Calling Line Identification Presentation (CLIP)
- Calling Line Identification Restriction (CLIR)
- Unstructured supplementary Services Mobile Originated Data (USSD)
- Closed user group

Internet Protocol:

- Embedded TCP/IP stack, including TCP/IP, UDP, SMTP and FTP protocol

Additional Features:

- SIM phonebook
- Fixed dialling number (FDN)
- Real time clock
- Network LED support
- IRA character set
- Jamming detection & report

Other features:

- Same mounting holes as Siemens / Cinterion TC35, MC35 Terminal

8 CEP Certified Accessories

	Product	Description
12002	Power supply 230V AC / 12 V DC	6pin RJ11 connector
12003	Power cable	6pin RJ11 connector with open ends
12021	Magnetic Antenna / Pentaband (Quad&UMTS)	FME female
12016	Rectangular Antenna / Pentaband (Quad&UMTS)	FME female
12020	Patch Antenna/ Pentaband (Quad&UMTS)	
12006	Roof-mount antenna*	FME female waterproof, 900/1800 MHz
12004	RS232 cable	1.5m for PC connection
	Mini USB cable for Audio / GPIOs	Mini USB connector with open ends
	Mini USB cable for Audio Mini connector	
	Mini USB cable for Audio RJ11	

Table 8: Accessories List

Please contact your distributor or CEP AG for availability or check CEP's webpage www.cepag.de.

9 Abbreviations

Abbreviation	Explanations
CBM	Cell Broadcast Message
CBS	Cell Broadcast Service
CSD	Circuit Switched Data
DCE	Data Circuit Terminating Equipment
DTE	Data Terminal Equipment
DTMF	Dual Tone Multi Frequency
EFR	Enhanced Full Rate
EMC	Electro-Magnetic Compatibility
ETSI	European Telecommunication Standards Institute
FR	Full Rate
GPRS	General Packet Radio Service
GSM	Global System for Mobile Communication
HR	Half Rate
HSCSD	High Speed Circuit Switched Data
ITU-T	International Telecommunication Union - Telecommunications Standardisation Sector
ME	Mobile Equipment
MO	Mobile Originated
MS	Mobile Station
MT	Mobile Terminated
PDU	Protocol Data Unit
RLP	Radio Link Protocol
RF	Radio Frequency
RTC	Real Time Clock
SIM	Subscriber Identity Module
SMS	Short Message Service
TA	Terminal Adapter
TE	Terminal Equipment
TS	Telecom Services
VSWR	Voltage Standing Wave Ratio

Table 9: Abbreviation

10 Mark of Conformity

The HT63-E Terminal will carry the following certificates:

CEP
Aktiengesellschaft
Cellulare Produkte

CEP AG
Cellulare Produkte
Raiffeisenallee 12b
82041 Oberhaching
Telefon 089 / 450292-0
Telefax 089 / 450292-

CE Declaration of Conformity

Hereby, we declare that our product **HT63 E** is in conformance with the EU directives / standards:

DIN EN 55022; VDE 0878-22:2011-12

„Information technology equipment – Radio disturbance characteristics – Limits and methods of measurement (CISPR 22)“

DIN EN 55024; VDE 0878-24:2011-09

„Information technology equipment – Immunity characteristics – Limits and methods of measurement (CISPR 24)“

DIN EN 61000-4-2
DIN EN 61000-4-3
DIN EN 61000-4-4
DIN EN 61000-4-5
DIN EN 61000-4-6
DIN EN 61000-4-8
DIN EN 61000-4-11

Oberhaching, 15th October 2013

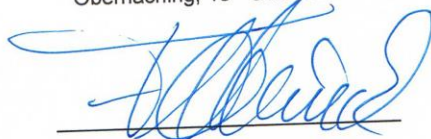

Frank Heineck; Board Member

Our product

HT63 E

is based on the GSM/UMTS module EHS5-E from the manufacturer Cinterion Wireless Modules GmbH. The GSM module of the manufacturer Cinterion Wireless Modules GmbH used here has been tested by the company CETECOM ICT Services GmbH in Saarbrücken (Germany).

The conformity of the module EHS5-E with the essential requirements of the European Directive 1999/5/EC has been verified against the following harmonized standards:

Health and Safety:	IEC 60950-1:2006+A11:2009+A1:2010+A12:2011 EC Council Recommendation 1999/519/EC
EMC:	EN 301 489-1 v1.9.1; EN 301 489-7 v1.3.1 ; EN 301 489-24 v1.5.1

All AC/DC adapters supplied by CEP AG comply with the standards:

CE / EN 60950:2009

11 Service and Support

To contact customer support please use the contact details below:

Customer Support

CEP AG

Raiffeisenallee 12b

82041 Oberhaching

Germany

E-mail: support@cepag.de

or

Tel. +49-89-450 292 – 11

Information about CEP AG, products and accessories is available on the following web site:
<http://www.cepag.de>.

Please contact us via e-mail if you miss anything on the web and we will provide it to you personally via e-mail.



CEP AG may, at any time and without notice, make changes or improvements to the products and services offered and / or cease producing or commercializing them.

12 Documentation Change Log

Revision	Date	Changes
Rev 1.2	21.03.2014	Update Document Layout
Rev 1.3	26.03.2014	Update Section 7

Table 10: Documentation Change Log